



Original Instruction

**OWNER'S (OPERATOR'S) MANUAL
AND SAFETY INSTRUCTIONS
FOR KITO PLAIN AND GEARED TROLLEY**

TS SERIES

ALWAYS SAVE THIS BOOK FOR FUTURE REFERENCE.

KITO

Issued September 1994. Revised May, 2016 (revision 11)

CONTENTS

1. DEFINITIONS.....	1
2. INTENDED PURPOSE.....	1
3. BEFORE USE	1
3.1 Safety summary	1
3.2 Safety instructions.....	2
4. MAIN SPECIFICATIONS	4
5. INSTALLATION	6
5.1 Coupling with manual chain hoists.....	6
5.2 Coupling with electric chain hoists.....	7
5.3 Adjusting trolley width before installation	10
5.4 Installation of trolley onto beam	10
5.5 Installation of stopper onto traversing beam.....	11
5.6 Check points after installation	11
6. OPERATION.....	11
6.1 Intended purpose of trolley operation	11
6.2 Safety working environment.....	11
6.3 Operation	11
6.4 Trolley storage	12
7. INSPECTION	12
7.1 Outline	12
7.2 Daily inspection	12
7.3 Periodic inspection.....	13
8. MAINTENANCE	16
8.1 Lubrication.....	16
8.2 Overhaul and assembly	16
9. BUFFER	18
9.1 Buffer.....	18
10. WARRANTY	19
11. PARTS LIST	20
12. CONTENTS OF EC DECLARATION OF CONFORMITY.....	25

1. DEFINITIONS

⚠ WARNING : indicates a potentially hazardous situation which, if not avoided, could result in death or serious injury.

⚠ CAUTION : indicates a potentially hazardous situation which, if not avoided, may result in minor or moderate injury. It may also be used to alert against unsafe practices.

WLL: indicates maximum mass (working load limit) which a trolley is designed to support in general service.

2. INTENDED PURPOSE

This trolley is designed for horizontally transporting loads by hand, through manual or electric hoist under normal atmospheric conditions of the work place.

3. BEFORE USE

3.1 Safety summary

Danger exists when heavy loads are transported, particularly when the equipment is not being used properly or is poorly maintained. Because accidents and serious injury could result, special safety precautions apply to the operation, maintenance and inspection of the KITO plain and geared trolley TS series.

The safety factor of the trolley is 4:1. The hoist may lift and hold a load more than the rated loads check that structure for mounting the trolley has sufficient strength.

⚠ WARNING

NEVER use a trolley for transporting people.

NEVER transport loads over or near people.

NEVER transport more than WLL which is shown on the name plate.

ALWAYS let people around you know when a transport is about to begin.

ALWAYS read the operation and safety instructions.

Remember proper handling techniques are the responsibility of the operator. Check all applicable safety codes, regulations and other applicable laws for further information about the safe use of your trolley.

More detailed safety information is contained in the following pages. For additional information, please contact KITO Corporation or your authorized KITO dealer.

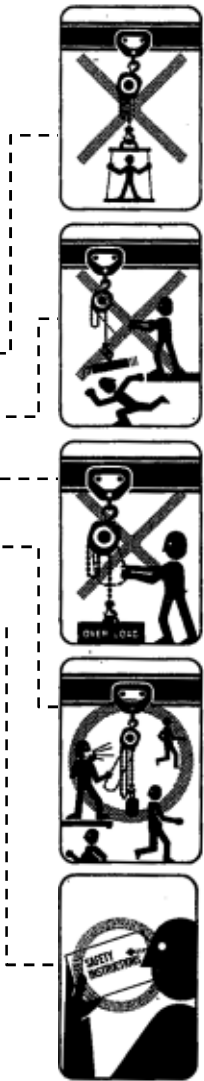

3.2 Safety instructions

⚠ WARNING

If this trolley is used in conjunction with a hoist, also refer to the hoist manual for additional precautions and instructions.

3.2.1 Before use

- ALWAYS** be sure to wear the proper clothing and personal protective equipment when using and operating the product.
- ALWAYS** allow the instructed (trained in safety and operation) people to operate the trolley.
- ALWAYS** oil the trolley regularly (Refer to 8.1).
- ALWAYS** rig the load properly and carefully.
- ALWAYS** check the trolley according to the “Daily inspection” (Refer to 7.2)
- NEVER** use a trolley if the width does not fit the rail.
- NEVER** connect the hoist to the trolley with improper fittings.
- NEVER** use a trolley without a name plate.

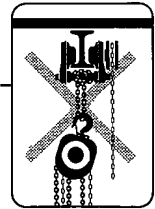
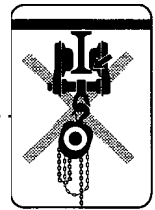

3.2.2 While operation

- ALWAYS** make sure that the load does not get in a way of hand chain.
- ALWAYS** when any abnormality is observed during the operation, stop the operation immediately, indicate “FAILURE” and contact with the maintenance engineers.
- ALWAYS** when inspecting and repairing, be sure to indicate “INSPECTION” and carry out without lifting a load.
- NEVER** strike a trolley intentionally to the stopper.
- NEVER** swing a suspended load.
- NEVER** weld or cut a load suspended by the trolley.
- NEVER** allow a trolley to collide with another trolley.
- NEVER** operate trolley unless load is centered under trolley.

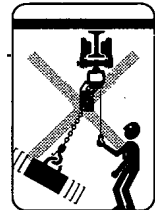
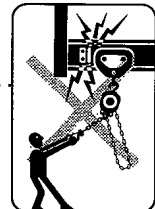

3.2.3 After operation

- NEVER** leave a suspended load unattended.
- NEVER** throw a trolley.

3.2.4 Maintenance

- ALWAYS** let the qualified service personnel inspect the trolley periodically (Refer to 7.3).

3.2.5 Others

ALWAYS consult the manufacturer or your dealers if you plan to use a trolley in an excessively corrosive environment. (Salt water, sea air and/or acid, explosive environment or other corrosive compounds, etc.).

ALWAYS when not in use of the trolley store it at dry place where appropriate for the weight and size.

ALWAYS use a trolley within rail slope of 1 degree.

ALWAYS when transferring including handling, and storing the product, carry it out carefully making sure of the product's weight and size.

NEVER use a trolley which has been taken out of service until the trolley has been properly repaired or replaced. -----

NEVER remove or obscure the warning stickers. -----

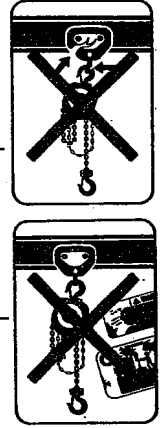

4. MAIN SPECIFICATIONS

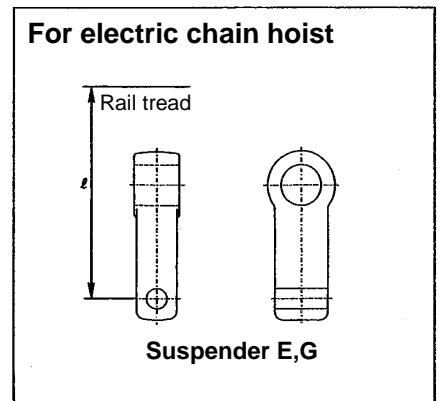
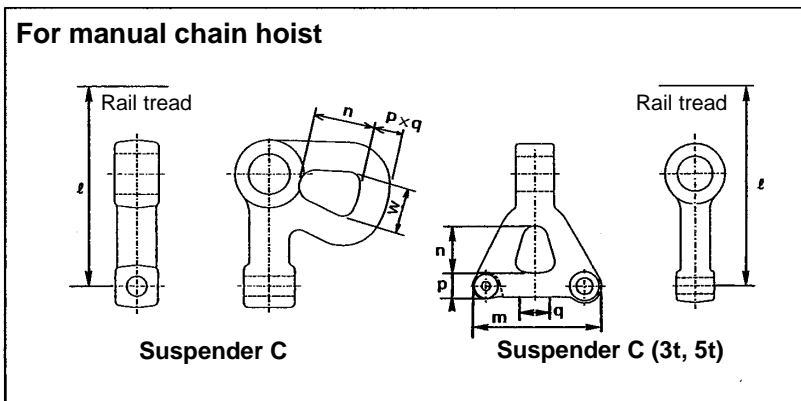
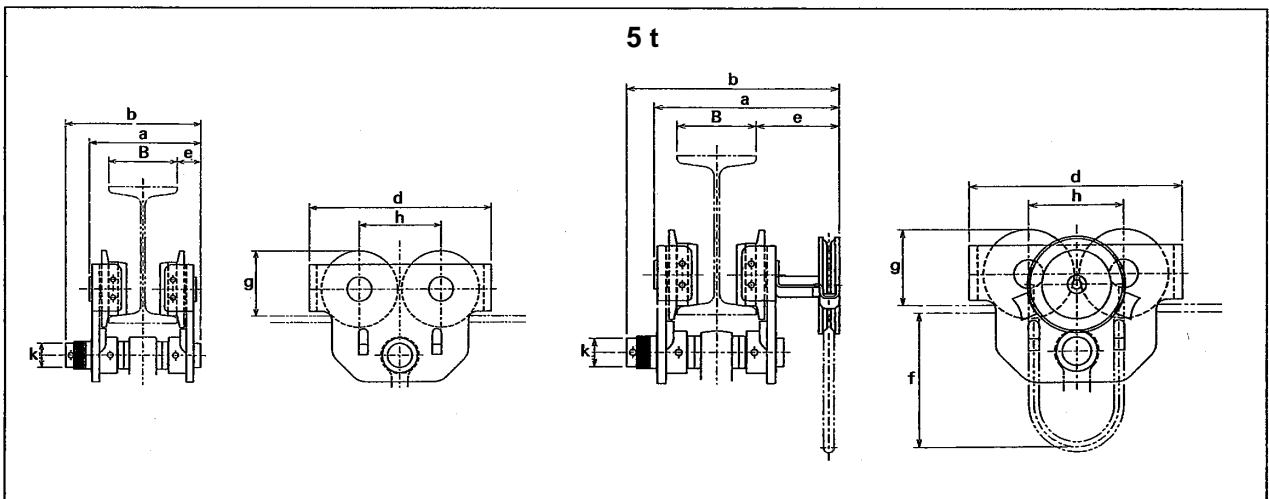
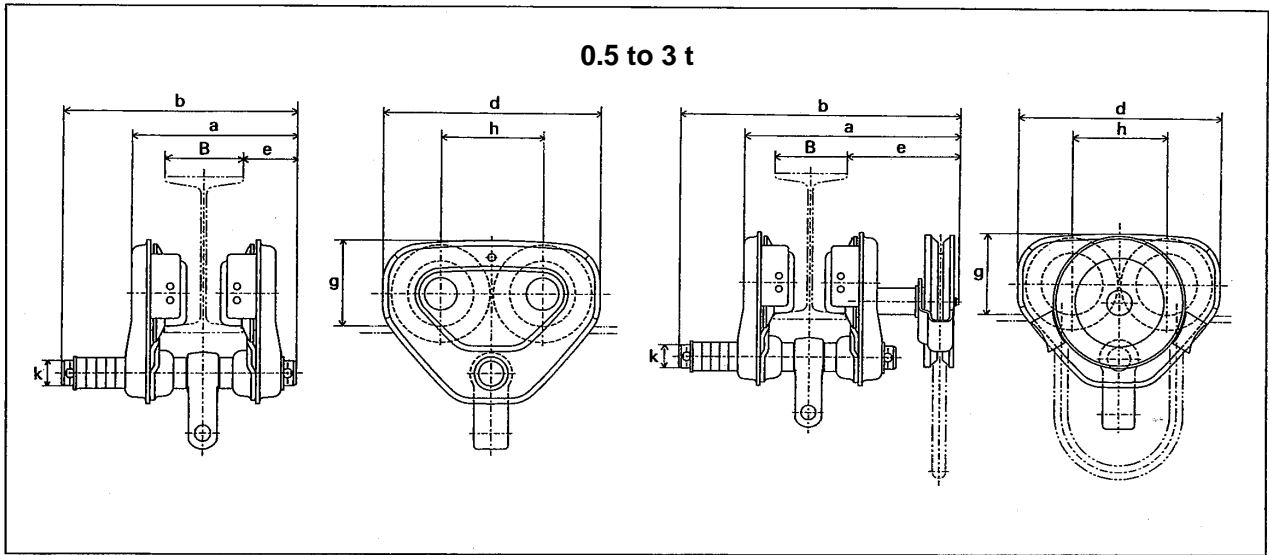

Code/C ⁽¹⁾ or E ⁽²⁾		WLL (t)	Rail width adjustability (mm)		Min radius for curve (mm)	Net Weight (kg)		Hand chain folded length (m)		a [Max.] (mm)	
Plain trolley	Geared trolley		Standard	Option		TSP	TSG	C ⁽¹⁾	E ⁽²⁾	C ⁽¹⁾	E ⁽²⁾
				W30							
TSP005C (E)	TSG005C(E)	0.5	50 to 163	164 to 305	1100 ⁽³⁾	4.5	—	—	—	173	173
TSP010C (E)	TSG015C (E)	1	58 to 163	164 to 305	1300 ⁽³⁾	8	12	2.5	3	275 (215)	311 (215)
TSP015C	TSG015C	1.5	82 to 163	164 to 305	1500	14	18	2.5	2.5	349 (264)	—
TSP020C (E)	TSG020C (E)	2	82 to 204	205 to 305	1500	14	19	3	3	349 (264)	349 (264)
TSP025C (E)	TSG025C (E)	2.5	82 to 204	205 to 305	1700	23	27	3	3	359 (280)	359 (280)
TSP030C (E)	TSG030C (E)	3	82 to 204	205 to 305	1700	23	27	3	3	359 (280)	359 (280)
TSP050C (E)	TSG050C (E)	5	100 to 204	205 to 305	2300	50	56	3.5	3.5	376 (273)	376 (273)

Code/C ⁽¹⁾ or E ⁽²⁾		WLL (t)	b (mm)		d (mm)	e (mm)		f (m)		g (mm)	h (mm)	k (mm)	ℓ (mm)		m (mm)	n (mm)	p (mm)	q (mm)
Plain trolley	Geared trolley		C ⁽¹⁾	E ⁽²⁾		C ⁽¹⁾	E ⁽²⁾	C ⁽¹⁾	E ⁽²⁾				C ⁽¹⁾	E ⁽²⁾				
TSP005C (E)	TSG005C(E)	0.5	204	204	182	46	46	2.7	2.7	76	84	22	93	98	26	33	14	14
TSP010C (E)	TSG010C (E)	1	309 (249)	345 (249)	236	116 (56)	152 (56)	2.2	2.7	95	112	25	106	—	28	37	18	18
TSP015C	TSG015C	1.5	385 (300)	—	280	154 (69)	—	2.2	—	112	131	32	129	119	32	40	22	22
TSP020C (E)	TFG020C (E)	2	385 (300)	385 (300)	280	154 (69)	154 (69)	2.7	2.7	112	131	32	129	138	32	40	22	22
TSP025C (E)	TSG025C (E)	2.5	398 (320)	398 (320)	324	157 (79)	157 (79)	2.7	2.7	134	152	36	144	153	36	44	27	25
TSP030C (E)	TSG030C (E)	3	398 (320)	398 (320)	324	157 (79)	157 (79)	2.7	2.7	134	152	36	169	153	40	48	24	30
TSP050C (E)	TSG050C (E)	5	401 (297)	401 (297)	400	156 (53)	156 (53)	3.2	3.2	144	178	54	228	171	60	70	33	36

Note: (1) C: For manual chain hoist.

(2) E: For electric chain hoist.

(3) Minimum flange width for curved rail;

(a) 0.5t trolley.....57 mm

(b) 1t trolley.....73 mm

(c) 2.5t and 3t trolley.....89 mm

Remark : 1) Figures in parentheses show the data for plain trolley type.

2) The maximum 300mm rail width are available as option.

3) Net weight is when flange width is in standard range.

4) Dimension “a” is when flange width is adjusted to the maximum of the standard range.

5) Dimension “b” is when flange width is in standard range.

Allowable ambient conditions;

Operation temperature: -40°C to +60°C: (-20°C to +40°C for the use with an electric chain hoist)

Operation humidity: 100%

Note:

- Install the trolley at the level an operator is able to operate the hand chain on the ground.
- If the adjustment of the bottom of the hand chain between 500 mm and 1000 mm from the ground is required, consult KITO.
- The rail that the trolley to be installed on should not have deflection exceeding 1/800 the span and/ or longitudinal slope of the traveling surface exceeding 0.25%.

This device was tested on the required static and dynamic test provided on the European standard EN13157.

5. INSTALLATION

5.1 Coupling with manual chain hoists

- (1) The M3 series hoist can be coupled either in the hook suspension method (the top hook is hung from the suspender C as shown in Fig. 5-1), or in the direct coupling method (the hoist body, with the top hook removed, is directly coupled to the suspender C as shown in Fig.5-2).

However the 7.5t and larger capacity M3 series hoist can only be suspended by the hook suspension method and the top hook must be hung from the suspension shaft of the trolley.

The CF series hoist can be suspended with suspender C like Fig.5-3.

- (2) The hook suspension method type is best for circumstances when the chain hoist is transferred frequently.

The direct coupling method is best for circumstances which require as much effective hoisting length as possible, especially where the height of ceiling is low.

- (3) Direct coupling method of M3 series chain hoist.

- (a) For 0.5 to 2.5t (Refer to Fig.5-4)

- 1) Remove the wheel cover nuts and the spring washers, then remove the wheel cover.
- 2) Remove the split pin from the top pin, then remove the top pin and the top hook.
- 3) Mount the suspender C to the hoist body with the top pin and the split pin which have been removed as above.
- 4) Securely bend the split pin as shown in Fig.5-5
- 5) Install the wheel cover, as it was before, with the nuts and the spring washers.

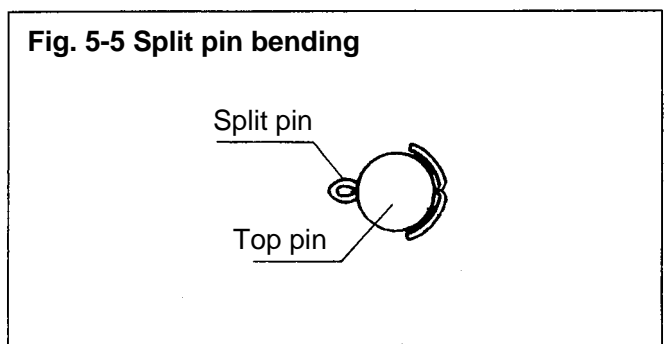
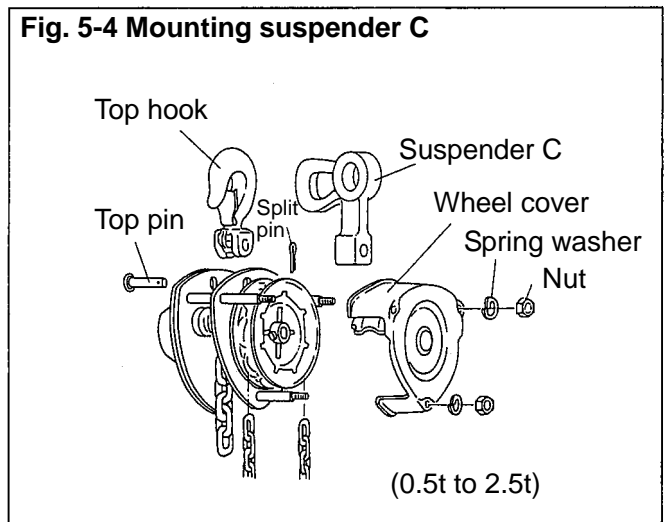
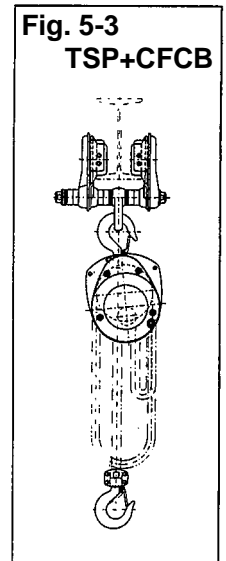
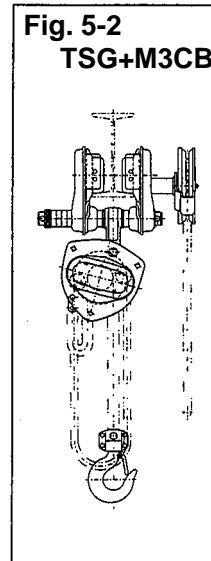
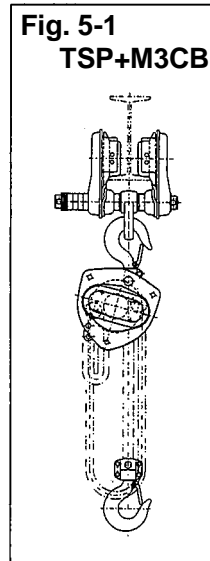

(b) For 3 or 5t (Refer to Fig. 5-6)

In addition to the procedure stated earlier, the following steps are also required.

- 1) Remove the split pin (from the slotted nuts), and then remove the slotted nut, the chain pin and the load chain from the top hook.
- 2) Connect the end of the load chain and the suspender C with the chain pin, the slotted nut and the split pin.
- 3) Bend securely the split pin.
- 4) Make sure that no twisting and no capsizing of the load chain occurs.

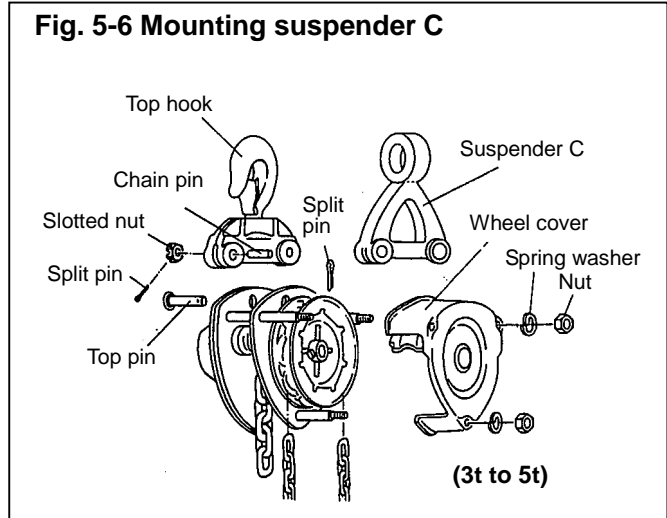

5.2 Coupling with electric chain hoists

5.2.1 ES, EF series

The direct coupling method shown in Fig. 5-9 should be applied.

- (1) Remove the split pin, the slotted nut and the top pin (in the case of double falls of the chain, the top bolt), and then remove the top hook. (Refer to Fig. 5-7).
- (2) Mount the suspender E to the hoist body with the top pin (or the top bolt) and the slotted nut which have been removed as above. Then insert a new split pin and bend it securely as shown in Fig. 5-5 on page 6.
- (3) The EF series electric chain hoist can be suspended by the suspender E like Fig. 5-10.

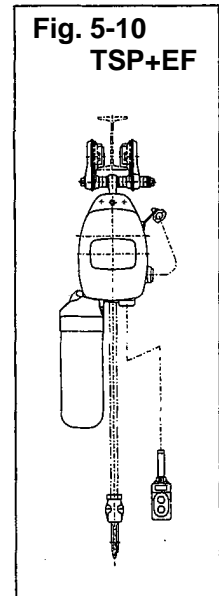
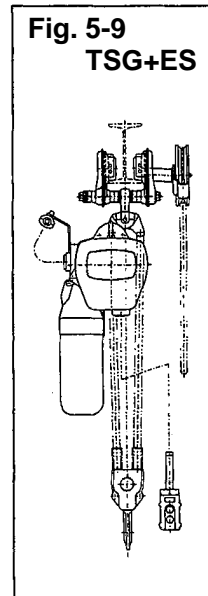
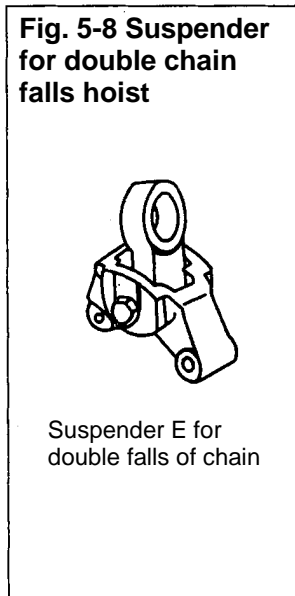
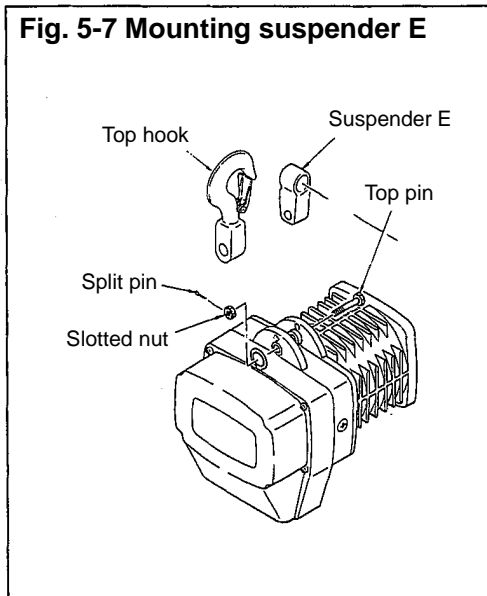

Table 5.1 Adjusting spacers arrangement on suspension shaft

Capacity (t)		Parts Name	Beam flange width (mm)																																		
Plain trolley	Geared trolley		50	58	66	74	82	90	91	98	106	113	119	125	131	137	143	144																			
125kg 250kg 500kg		Thin spacer	Inner	2	3	4	4	1	1	2	3	3	4	1	1	1	1	2	2	3	4	4	5	1	2	2	3	3	4	0	1	1	2	1	2		
			Outer	7	4		10	7	5	10	10	8	5	3	9	7	5	11	9	9																	
		Thick spacer	Inner	0	0	0	0	1	1	1	1	1	1	2	2	2	2	2	2	2	2	2	2	2	2	3	3	3	3	3	3	4	4	4	4	4	
			Outer	8	8	6	6	6	6	4	4	4	4	4	4	2	2	2	0	0	0																
		Fixing spacer	Inner	0	0	0	0	0	0	0	0	0	0	0	0	0	0	0	0	0	0	0	0	0	0	0	0	0	0	0	0	0	0	0	0		
			Outer	0	0	0	0	0	0	0	0	0	0	0	0	0	0	0	0	0	0	0	0	0	0	0	0	0	0	0	0	0	0	0	0	0	
1t	125kg 250kg 500kg 1t	Thin spacer	Inner			3	4	0	1	2	2	3	3	0	1	0	1	1	2	3	3	4	4	1	1	2	2	3	3	0	0	1	1	1	1		
			Outer			4	10	7	5	10	10	8	5	3	9	7	5	11	9	9																	
		Thick spacer	Inner			0	0	1	1	1	1	1	1	2	2	2	2	2	2	2	2	2	2	2	3	3	3	3	3	3	4	4	4	4	4	4	
			Outer			8	8	6	6	6	6	4	4	4	4	4	2	2	2	0	0	0															
		Fixing spacer	Inner			0	0	0	0	0	0	0	0	0	0	0	0	0	0	0	0	0	0	0	0	0	0	0	0	0	0	0	0	0	0	0	
			Outer			0	0	0	0	0	0	0	0	0	0	0	0	0	0	0	0	0	0	0	0	0	0	0	0	0	0	0	0	0	0	0	0
1.6t 2t		Thin spacer	Inner							2	3	0	0	0	0	1	2	2	3	3	4	4	0	1	1	2	2	3	3	4	0	1	0	1			
			Outer							2	7	7	4	2	0	6	4	2	0	6	4	2	0	6	6												
		Thick spacer	Inner							0	0	1	1	1	1	1	1	1	1	1	1	1	1	2	2	2	2	2	2	2	2	2	2	3	3	3	3
			Outer							10	8	8	8	8	8	8	6	6	6	6	6	4	4														
		Fixing spacer	Inner							0	0	0	0	0	0	0	0	0	0	0	0	0	0	0	0	0	0	0	0	0	0	0	0	0	0	0	0
			Outer							0	0	0	0	0	0	0	0	0	0	0	0	0	0	0	0	0	0	0	0	0	0	0	0	0	0	0	0
2.5t 3.2t		Thin spacer	Inner							2	3	3	4	3	4	1	1	2	2	3	3	4	4	1	1	2	2	3	3	4	4	0	1				
			Outer							9	7	7	12	10	8	6	12	10	8	6	13																
		Thick spacer	Inner							2	2	2	2	2	2	3	3	3	3	3	3	3	3	4	4	4	4	4	4	4	4	4	4	4	5	5	
			Outer							8	8	8	6	6	6	6	6	6	4	4	4	4	4														
		Fixing spacer	Inner							0	0	0	0	0	0	0	0	0	0	0	0	0	0	0	0	0	0	0	0	0	0	0	0	0	0	0	0
			Outer							0	0	0	0	0	0	0	0	0	0	0	0	0	0	0	0	0	0	0	0	0	0	0	0	0	0	0	0
5t		Thin spacer	Inner															1	1	2	3	3	3	0	0	1	1	2	2	3	3	3	3				
			Outer																10	7	6	12	10	8	6	6											
		Thick spacer	Inner																0	0	0	0	0	0	1	1	1	1	1	1	1	1	1	1	1		
			Outer																6	6	6	4	4	4	4	4	4	4	4	4	4	4	4	4	4		
		Fixing spacer	Inner																0	0	0	0	0	0	0	0	0	0	0	0	0	0	0	0	0	0	
			Outer																0	0	0	0	0	0	0	0	0	0	0	0	0	0	0	0	0	0	

NOTE: 1) Adjustment of trolley width.

Refer to 5.3 on page 9.

Adjust the dimensions by appropriately increasing or decreasing the number of inner or outer adjusting spacers, without strictly adhering to the number of adjusting spacers shown in the above table.

2) Thick Spacer and Thin Spacer in white and Fixing Spacer in black.

Capacity (t)		Parts Name		Beam flange width (mm)																																
Plain trolley	Geared trolley			149	155	163	170	178	185	200	201	204	210	220	240	260	280	300	305																	
125kg 250kg 500kg		Thin spacer	Inner	2	3	3	4	4	5	0	0	1	1	2	2	0	1	1	1	1	2	2	4	4	3	3	2	2	1	2	4	5	2	5		
			Outer	7	5	3	9	7	5	8	7	6	5	1	3	5	6	0	2																	
		Thick spacer	Inner	4	4	4	4	4	4	3	3	3	3	4	4	4	4	4	4	4	4	4	4	4	4	5	5	6	6	7	7	7	7	8	7	
			Outer	0	0	0	9	9	9	7	7	7	7	7	7	5	3	1	1	0																
		Fixing spacer	Inner	0	0	0	0	0	1	1	1	1	1	1	1	1	1	1	1	1	1	1	1	1	1	1	1	1	1	1	1	1	1	1		
			Outer	0	0	0	0	0	0	0	0	0	0	0	0	0	0	0	0	0																
1t	125kg 250kg 500kg	Thin spacer	Inner	2	2	3	3	4	4	0	0	1	1	2	2	0	1	1	1	1	2	2	2	2	4	4	3	3	2	2	1	2	4	5	2	5
			Outer	7	5	3	9	7	5	8	7	6	5	1	3	5	6	0	2																	
	1t	Thick spacer	Inner	4	4	4	4	4	4	2	2	2	2	2	2	3	3	3	3	3	3	3	3	3	3	4	4	5	5	6	6	6	6	7	6	
			Outer	0	0	0	9	9	9	7	7	7	7	7	5	3	1	1	0																	
	1t	Fixing spacer	Inner	0	0	0	0	0	1	1	1	1	1	1	1	1	1	1	1	1	1	1	1	1	1	1	1	1	1	1	1	1	1	1		
			Outer	0	0	0	0	0	0	0	0	0	0	0	0	0	0	0	0																	
1.6t 2t	Thin spacer	Inner	1	2	2	3	3	4	1	1	2	2	3	3	1	2	2	2	2	2	2	2	4	4	3	3	2	2	1	2	4	5	2	5		
		Outer	4	2	0	5	3	1	4	3	3	5	1	3	5	6	0	2																		
	Thick spacer	Inner	3	3	3	3	3	3	4	4	4	4	4	4	5	5	5	5	5	5	2	2	2	2	3	3	4	4	5	5	5	5	6	5		
		Outer	4	4	4	2	2	2	0	0	0	7	7	5	3	1	1	0																		
	Fixing spacer	Inner	0	0	0	0	0	0	0	0	0	0	0	0	0	0	0	0	0	0	0	0	1	1	1	1	1	1	1	1	1	1	1	1		
		Outer	0	0	0	0	0	0	0	0	0	0	0	0	0	0	0	0																		
2.5t 3.2t	Thin spacer	Inner	1	1	2	2	3	3	0	1	1	2	3	3	5	5	5	6	5	6	2	2	4	4	3	3	2	2	1	2	4	5	2	5		
		Outer	12	10	8	13	11	8	4	3	3	5	1	3	5	6	0	2																		
	Thick spacer	Inner	5	5	5	5	5	5	6	6	6	6	6	6	6	6	6	6	6	2	2	2	2	3	3	4	4	5	5	5	5	6	5			
		Outer	2	2	2	0	0	0	0	0	0	7	7	5	3	1	1	0																		
	Fixing spacer	Inner	0	0	0	0	0	0	0	0	0	0	0	0	0	0	0	0	0	0	0	0	1	1	1	1	1	1	1	1	1	1	1	1		
		Outer	0	0	0	0	0	0	0	0	0	0	0	0	0	0	0	0																		
5t	Thin spacer	Inner	0	0	1	1	2	3	3	4	0	1	2	2	4	4	4	5	5	5	1	2	3	4	2	3	1	2	1	1	4	4	1	5		
		Outer	12	10	7	5	11	8	4	3	2	5	1	3	5	8	0	2																		
	Thick spacer	Inner	2	2	2	2	2	2	2	3	3	3	3	3	3	3	3	3	3	1	1	1	1	2	2	3	3	4	4	4	4	5	4			
		Outer	2	2	2	2	0	0	0	0	0	7	7	5	3	1	1	0																		
	Fixing spacer	Inner	0	0	0	0	0	0	0	0	0	0	0	0	0	0	0	0	0	0	0	0	1	1	1	1	1	1	1	1	1	1	1	1		
		Outer	0	0	0	0	0	0	0	0	0	0	0	0	0	0	0	0																		

Standard W30

NOTE: 3) Take note the numbers on spacers of inner side as follows.

Example of 0 + 1

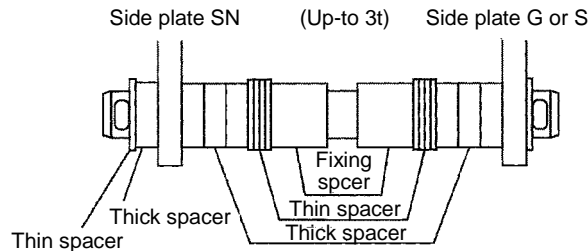
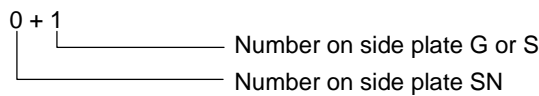

5.2.2 ER Series

The direct coupling method shown Fig. 5-14 should be applied.

Mount the suspender G to the connection yoke with the connection yoke rubber, the yoke bolt and the slotted nut. (Refer to Fig. 5-13) Then insert a split pin and bend it securely as shown in Fig. 5-5.

Please refer to an ER2 series owner's manual for coupling with the ER2 series.

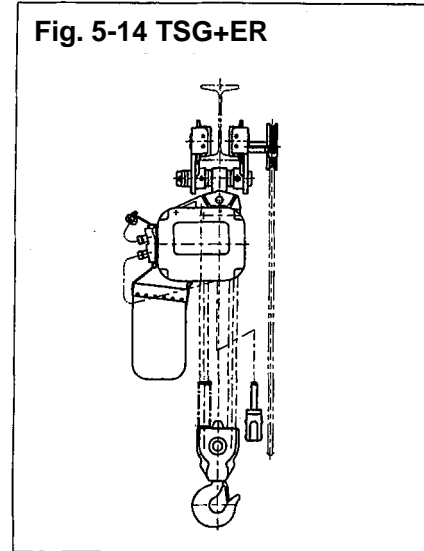
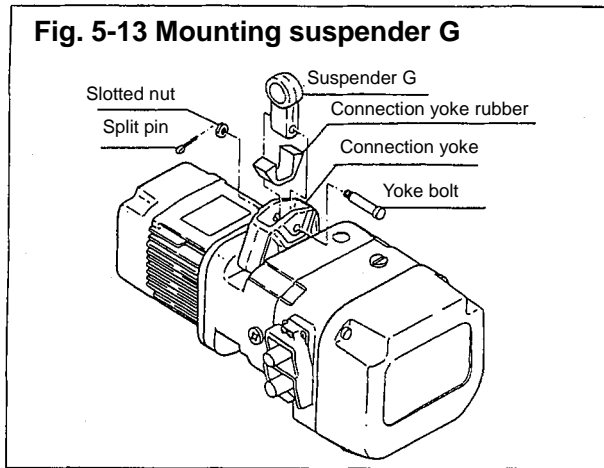

5.3 Adjusting trolley width before installation

When the trolley and the chain hoist are coupled, the trolley must be adjusted with the adjusting spacers (Refer to Table 5-1).

- (1) Make sure that the direction is as shown in Fig. 5-1, 5-2, 5-3, 5-9 or 5-10
- (2) The right and left side plates should be as far apart as possible, and difference between A and B should be approximately 4mm (Refer to Fig. 5-11)
- (3) Bend securely the split pin of the shaft stopper pin as shown in Fig. 5-12

Fig. 5-11 Trolley width adjustment

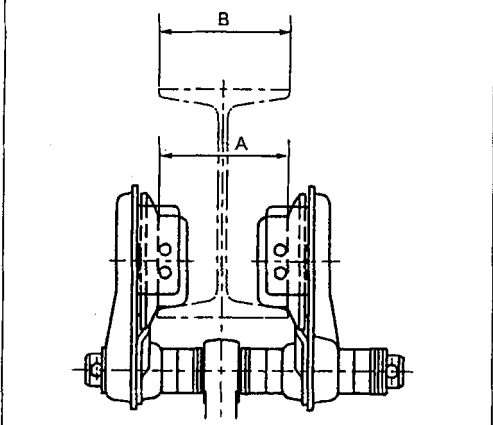

5.4 Installation of trolley onto beam

- (1) The preferred method of installation is from the end of the beam, with the chain hoist and the trolley coupled. After installation, make sure to re-install the stopper as it was.
- (2) When there is no space between the end of beam and building, first remove the side plate S (with name plate) from the suspension shaft. After placing the side plate G (or S without name plate) on the other side of the flange, re-assemble and re-install side plate S (with name plate) as it was before. Also, bend securely the split pin of the shaft stopper pin as shown in Fig. 5-12.

Remark: If using two or more trolleys on the same rail, separate them with a stopper between every two trolleys. Determine the distance between stoppers depending on site requirements, or contact KITO or a KITO authorized dealer for help.

Fig. 5-12 Split pin bending

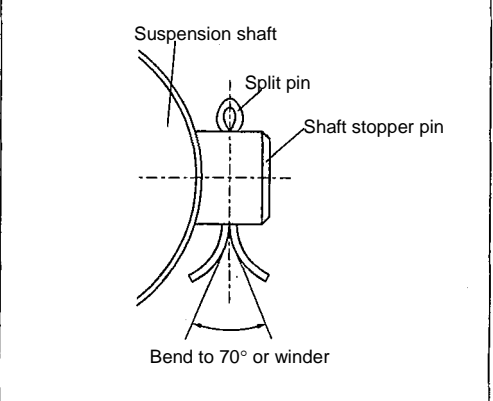

5.5 Installation of stopper onto traversing beam

Make sure to install the stoppers at the both ends of the beam.

5.6 Check points after installation

When the entire installation is completed, check the following.

- (1) Check whether the relation between the positions of the trolley and the chain hoist is correct (Refer to Fig. 5-1 to 5-2, 5-3, 5-9 or 5-10).
- (2) Check that the beam stoppers are securely fastened on the rail to prevent trolley run away.
- (3) Make sure that no bolt, nut, split pin or snap pin is missing, and that these are all adequately fastened.

6. OPERATION

6.1 Intended purpose of trolley operation

▲ WARNING

This trolley has been designed for horizontally transporting loads by hand, through manual or electric hoist under normal atmospheric conditions of the work place.

However, since dealing with heavy loads may involve unexpected danger, all the “Safety instructions” (Refer to 3.2) must be followed.

6.2 Safety working environment

▲ WARNING

The operator must be aware of the following points while using the trolley.

- (1) The operator must have a clear and unobstructed view of the entire travel area before operating the trolley.
When not possible, a second or more persons must serve as scouts in the nearby area.
- (2) The operator must check the entire travel area is safe and secure before operating the trolley.

6.3 Operation

▲ CAUTION

ALWAYS take care hand or clothes not to be caught in a track wheel or other moving parts.

- (1) Plain trolley
The trolley movement is controlled by pushing the load or the hook of the attached hoist.
- (2) Geared trolley
 1. Face the hand wheel side of the trolley.
 2. To move left, pull hand chain clockwise.
 3. To move right, pull hand chain counterclockwise.

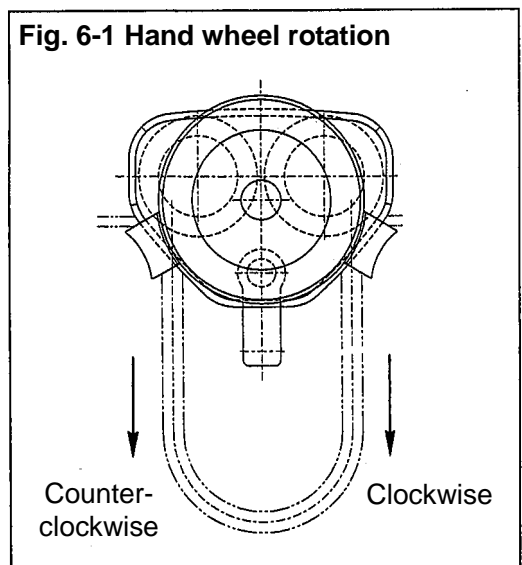

6.4 Trolley storage

⚠ CAUTION

Observe the following points when storing the trolley.

NEVER expose the trolley to rain or dew.

ALWAYS wipe off all dirt and water.

ALWAYS install in a dry place.

ALWAYS lubricate gear side of the pinion and track wheel G.

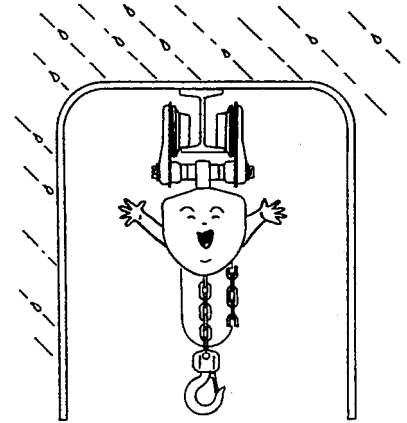

7. INSPECTION

7.1 Outline

There are two types of inspection, the daily inspection performed by the operator before using the trolley, and the more thorough periodic inspection performed by qualified service personnel who have the authority to remove the trolley from service.

7.2 Daily inspection

Before each work shift, check the following points;

Item	Inspection method	Discard limit/criteria	Remedy
1. Function	Run under no load condition.	Trolley should run smoothly and is not tilt when a light load is applied.	If the movement is not smooth, try to determine its cause and replace the trolley with a new one if necessary.
2. Wear, deformation and damage of each part	Check visually.	There should be no wear, deformation or damage.	Replace the part with new one if worn, deformed or damaged.
3. Part loosening	Check visually.	Parts should not be loosened.	Fasten tightly.
4. Name plate	Check visually.	Every description should be clear and visible.	Replace the name plate with new one.
5. Hand chain	Check visually	There should be no deformation or damage.	Replace the chain.
	Listen to the noise.	There should be no irregular noises.	Replace the chain or inspect the hand wheel.
6. Missing of parts	Check visually.	No missing nuts and/or split pins.	Replace the parts.

7.3 Periodic inspection

Periodic inspection shall be made at the interval shown below and should follow the given procedures.

NORMAL (Normal use) : Semiannual inspection
 HEAVY (Frequent use) : Quarterly inspection
 SEVERE (Excessively frequent use): Monthly inspection

Inspect all the items in “Periodic inspection” in addition to “Daily inspection” items.

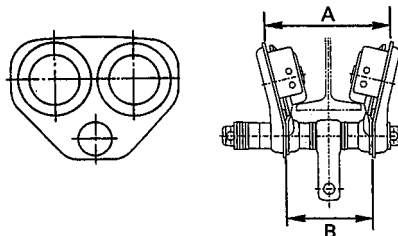
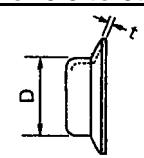
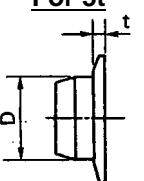
Item	Inspection method	Discard limit/criteria	Remedy																																		
1. Traversing function	Move trolley with light load suspended.	Trolley should run smoothly, and not tilt when a light load applied. Overall movement should be smooth.	If not smooth, adjust beam, re-adjust balance or lubricate pinion holder, pinion and gear of track wheel G.																																		
2. Side plate deformation	Check with calipers.	The difference of dimension “A” and “B” should not exceed 2mm. 	If the difference exceeds 2mm, replace it with a new one.																																		
3. Track wheel wear	Check visually or use calipers as needed. For 0.5 to 3t  For 5t 	Wear of flange tread should not be less than the limits on the table below. <table border="1" data-bbox="742 1243 1412 1523"> <thead> <tr> <th rowspan="2">WLL (t)</th> <th colspan="2">Larger tread diameter: D</th> <th colspan="2">Flange thickness: t</th> </tr> <tr> <th>Standard</th> <th>Limit</th> <th>Standard</th> <th>Limit</th> </tr> </thead> <tbody> <tr> <td>0.5</td> <td>60</td> <td>58.5</td> <td>3.2</td> <td>2.5</td> </tr> <tr> <td>1</td> <td>71</td> <td>69.5</td> <td>4</td> <td>3.3</td> </tr> <tr> <td>2</td> <td>85</td> <td>83.5</td> <td>4.5</td> <td>3.8</td> </tr> <tr> <td>3</td> <td>100</td> <td>98.5</td> <td>5</td> <td>4.3</td> </tr> <tr> <td>5</td> <td>118</td> <td>112</td> <td>9.6</td> <td>6.7</td> </tr> </tbody> </table>	WLL (t)	Larger tread diameter: D		Flange thickness: t		Standard	Limit	Standard	Limit	0.5	60	58.5	3.2	2.5	1	71	69.5	4	3.3	2	85	83.5	4.5	3.8	3	100	98.5	5	4.3	5	118	112	9.6	6.7	Replace it with a new one if it is less than the limit.
WLL (t)	Larger tread diameter: D			Flange thickness: t																																	
	Standard	Limit	Standard	Limit																																	
0.5	60	58.5	3.2	2.5																																	
1	71	69.5	4	3.3																																	
2	85	83.5	4.5	3.8																																	
3	100	98.5	5	4.3																																	
5	118	112	9.6	6.7																																	
4. Damage of hand wheel	Check visually	NEVER use the damaged one.	Replace it with new one.																																		

Item	Inspection method	Discard limit/ criteria	Remedy
5. Deformation and wear of gear (track wheel G, pinion)	Check visually or use calipers as needed.	NEVER use the deformed or worn one.	Replace it with new one.
6. Deformation and wear of suspension shaft	Check visually or use calipers as needed.	NEVER use the suspension shaft if its diameter is worn by 10% or more.	Replace it with new one.
7. Wear of suspender	Check visually or use calipers as needed.	NEVER use the suspender if its dimension of "D ₂ -D ₁ " or "d" exceeds the limit in the table below. NEVER use the suspender if dimension "h" is less than the limit in the table below.	Replace if it exceeds the limit. Replace if it is less than the limit.

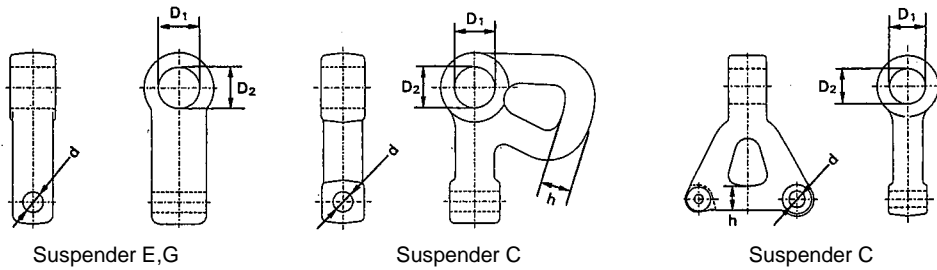

(mm)

Hoist type	WLL (t)	Hoist capacity(t)	D ₂ -D ₁ limit	d		h	
				Standard	Limit	Standard	Limit
CB (Susp.C)	0.5	0.5	1	12.2	13	14	12.5
	1	0.5, 1	1	12.2	13	18	16
	2	1.5, 1	1	16.2	17	22	20
				16.2	17	27	24
	3	3	1.5	16.4	17	24	21.5
5	5	1.5	16.4	17	33	30	
ES or EF (Susp. E), ER (Susp. G)	0.5	0.25, 0.5-S, 0.5-L	1	12.2	13	—	—
	1	1-S, 1-L	1	12.2	13	—	—
	2	1.5, 2-S, 2-L	1	20.2	21	—	—
	3	2.5, 2.8, 3	1.5	20.2	21	—	—
	5	5	1.5	28.2	30	—	—

8. Rail deformation	Check visually or use calipers as needed.	The flange should not be deformed.	Replace or repair.
9. Condition of welded part	Check visually.	There should be no crack. There should be no rust.	Repair or strengthen.
10. Rail wear	Check visually or use calipers as needed.	The tread should not be worn. Replace it if the dimension "B" becomes 95% or "t" becomes 90% of new one. Tapered flange Flat flange	Replace.

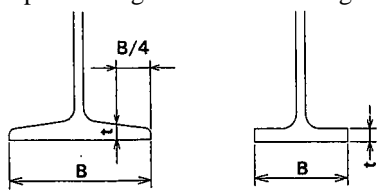

Item	Inspection method	Discard limit/ criteria	Remedy
11. Condition of wheels	Check visually.	<p>The trolley wheels should track the beam properly.</p> <p>Total clearance between wheels and flange equals 4mm.</p>	<p>Adjust or repair.</p> <p>Adjust the clearance if necessary.</p>
12. Loosening of fixing bolt	Try to turn it with a spanner.	The bolt should be tightened firmly.	Tighten the bolt.
13. Missing of rivets, split pins and nuts	Check visually.	Parts should not be missing.	Replace the missing parts.

8. MAINTENANCE

⚠ WARNING

- (1) **NEVER** perform maintenance on the trolley while it is supporting a load.
- (2) Before performing maintenance, attach the tag;
[“DANGER”: **NEVER OPERATE EQUIPMENT BEING REPAIRED.**]
- (3) Only allow qualified service personnel to perform maintenance.
- (4) After performing any maintenance on the trolley, **ALWAYS** test to WLL before returning to service.
- (5) When replacing a part, be sure to use the genuine part for “KITO plain and geared trolley TS series”.

⚠ CAUTION

ALWAYS indicate “CHECKING” when performing the inspection.

ALWAYS wear protection equipment such as protection goggles and gloves depending on the work contents.

ALWAYS pay attention to work method, work procedure and work posture.

ALWAYS wear helmet and safety belt when carrying the high lift work.

ALWAYS remove the oil or grease attached to the product or spilt on the floor.

ALWAYS keep the work area clean when disassembling the product.

ALWAYS take care hand or clothes not to be caught in a track wheel or other moving parts.

8.1 Lubrication

8.1.1 Geared wheels (geared trolley only)

Lubricate exposed trolley drive pinion and wheel teeth. Brush with grease as often as necessary to keep teeth liberally covered. If the grease becomes contaminated with sand, dirt or other worn materials, remove old greases and replace with new grease (standard grease ⁽¹⁾) during monthly or annual inspection.

Temperature range of standard grease is -40°C to +60°C.

If the trolley is used at temperature below -40°C or above +60°C, consult KITO or authorized KITO dealer since some parts shall be changed.

Remark :⁽¹⁾ Calcium soap grease equivalent of NLGI (National Lubricating Grease Institute)/#2 or EP 2.

8.1.2 Trolley wheels and hand chain

Trolley wheel bearings do not need to be lubricated and must be replaced if worn or damaged. Hand chain, used on geared trolleys, do not normally requires lubrication.

8.2 Overhaul and assembly

Overhaul and assembly should be performed with reference to the following Fig. 8-1 or 8-2.

- (1) For overhauling a geared trolley, remove the track wheel first, then take off the pinion.
- (2) Arrange the adjusting spacers as shown in Table 5-1.
- (3) In case that the geared trolley is coupled with the manual or electric chain hoist, the trolley’s hand chain should be on the right side facing the hoist’s name plate side.
- (4) Bend the split pin securely as shown in Fig. 8-1 or 8-2 after the installation is completed.
- (5) Place the shaft stopper pin as shown in Fig. 8-1 or 8-2, the flat surface should be touched on adjusting spacers.

Fig. 8-1 Trolley parts arrangement - for 3t and smaller

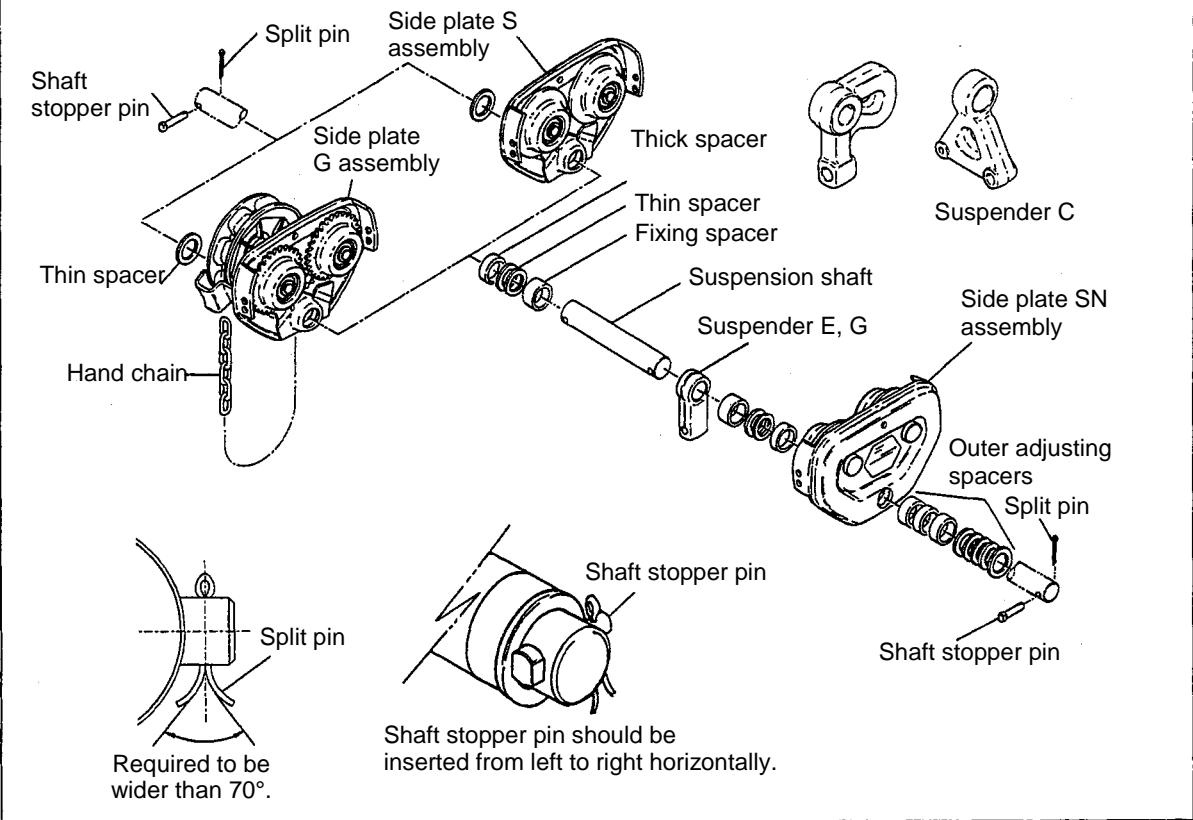
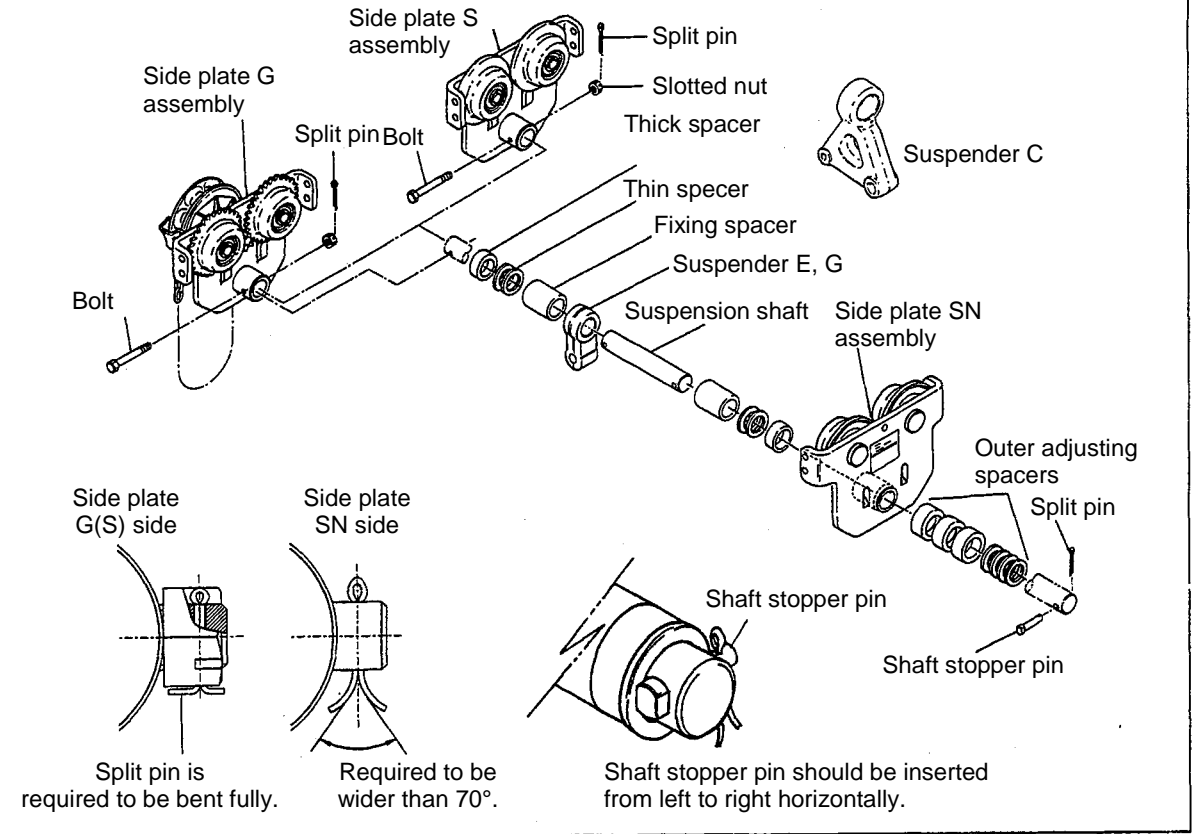

Fig. 8-2 Trolley parts arrangement - for 5t



9. BUFFER

9.1 Buffer

The side plate “S”, “SN” and “G” have bumpers which prevent damage to the wheel and to the trolley.

9.1.1 Installation of buffer

Assemble as described below. Tighten the screw securely so the buffer cannot be moved by hand.

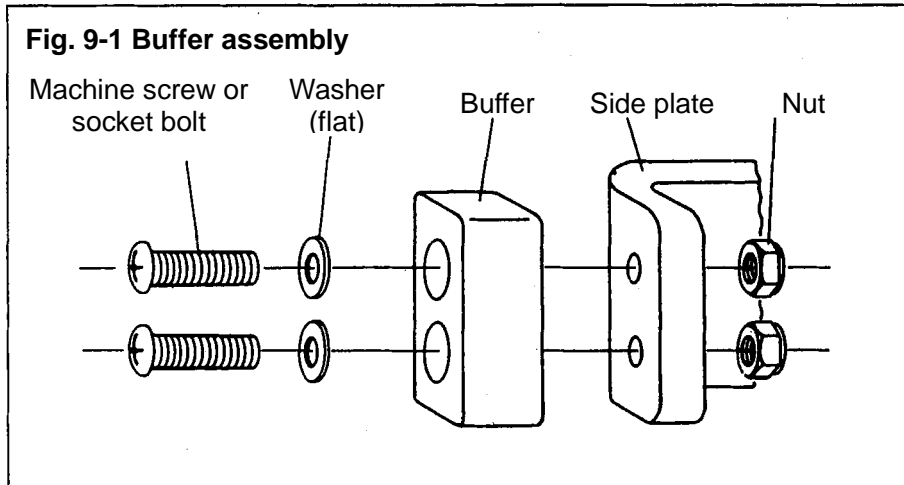

10. WARRANTY

KITO Corporation (“KITO”) extends the following warranty to the original purchaser (“Purchaser”) of new products manufactured by “KITO” (KITO’s Products).

- (1) “KITO” warrants that KITO’s Products, when shipped, shall be free from defects in workmanship and/ or materials under normal use and service and “KITO” shall, at the election of “KITO”, repair or replace free of charge any parts or items which are proven to have said defects, provided that all claims for defects under this warranty shall be made in writing immediately upon discovery and, in any event, within one (1) year from the date of purchase of KITO’s Products by “Purchaser” and provided, further, that defective parts or items shall be kept for examination by “KITO” or its authorized agents or returned to KITO’s factory or authorized service counter upon request by “KITO”.
- (2) “KITO” does not warrant components of products provided by other manufacturers. However to the extent possible, “KITO” will assign to “Purchaser” applicable warranties of such other manufacturers.
- (3) Except for the repair or replacement mentioned in (1) above which is “KITO”’s sole liability and purchaser’s exclusive remedy under this warranty, “KITO” shall not be responsible for any other claims arising out of the purchase and use of KITO’s Products, regardless of whether “Purchaser”’s claims are based on breach of contract, tort or other theories, including claims for any damages whether direct, indirect, incidental or consequential.
- (4) This warranty is conditional upon the installation, maintenance and use of KITO’s Products pursuant to the product manuals prepared in accordance with content instructions by “KITO”. This warranty shall not apply to KITO’s Products which have been subject to negligence, misuse, abuse, misapplication or any improper use or combination or improper fittings, alignment or maintenance.
- (5) “KITO” shall not be responsible for any loss or damage caused by transportation, prolonged or improper storage or normal wear and tear of KITO’s Products or for loss of operating time.
- (6) This warranty shall not apply to KITO’s Products which have been fitted with or repaired with parts, components or items not supplied or approved by “KITO” or which have been modified or altered.

THIS WARRANTY IS IN LIEU OF ALL OTHER WARRANTIES, EXPRESS OR IMPLIED, INCLUDING BUT NOT LIMITED TO ANY WARRANTY OF MERCHANTABILITY OR OF FITNESS FOR A PARTICULAR PURPOSE.

11. PARTS LIST

When ordering replacement parts please specify WLL, Fig. No., part name and quantity.

Plain trolley (Rail width - standard)

Fig. 12-1 Parts development - 3t and smaller plain trolleys (for normal rail width)

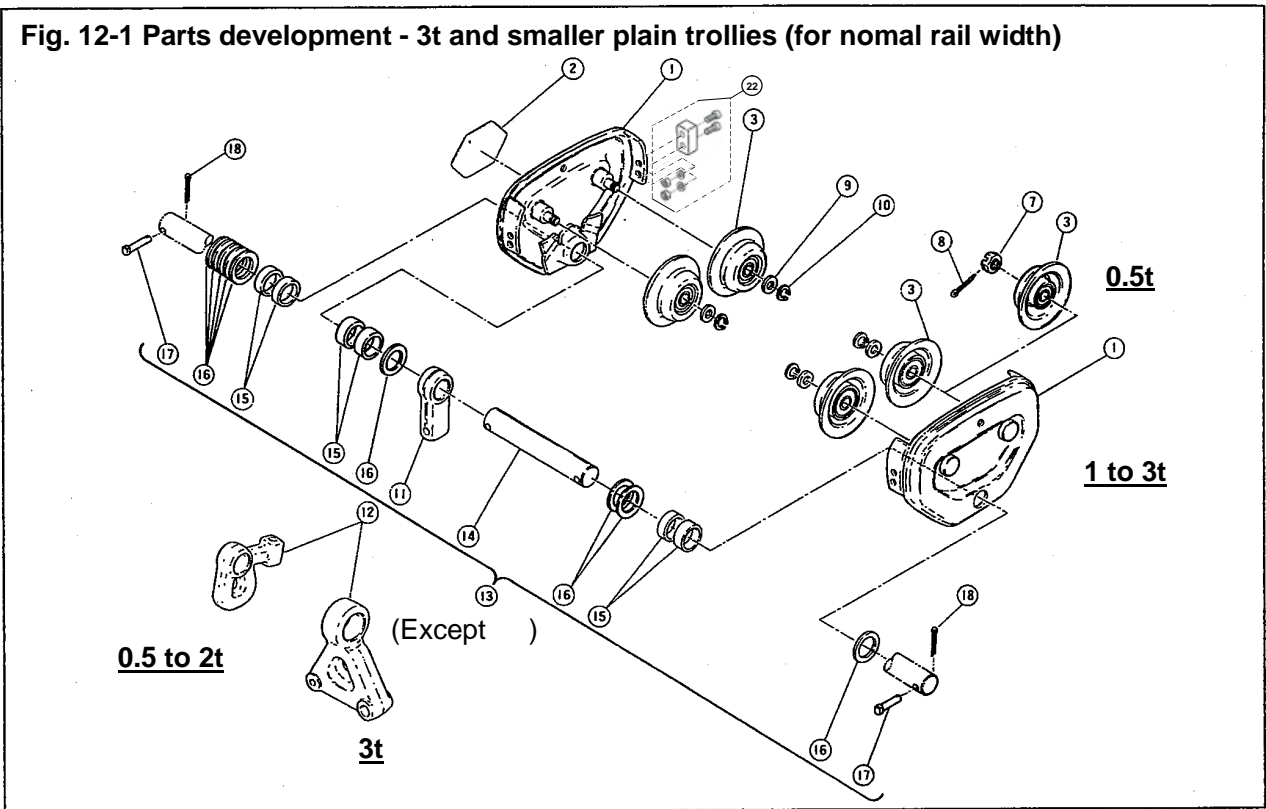
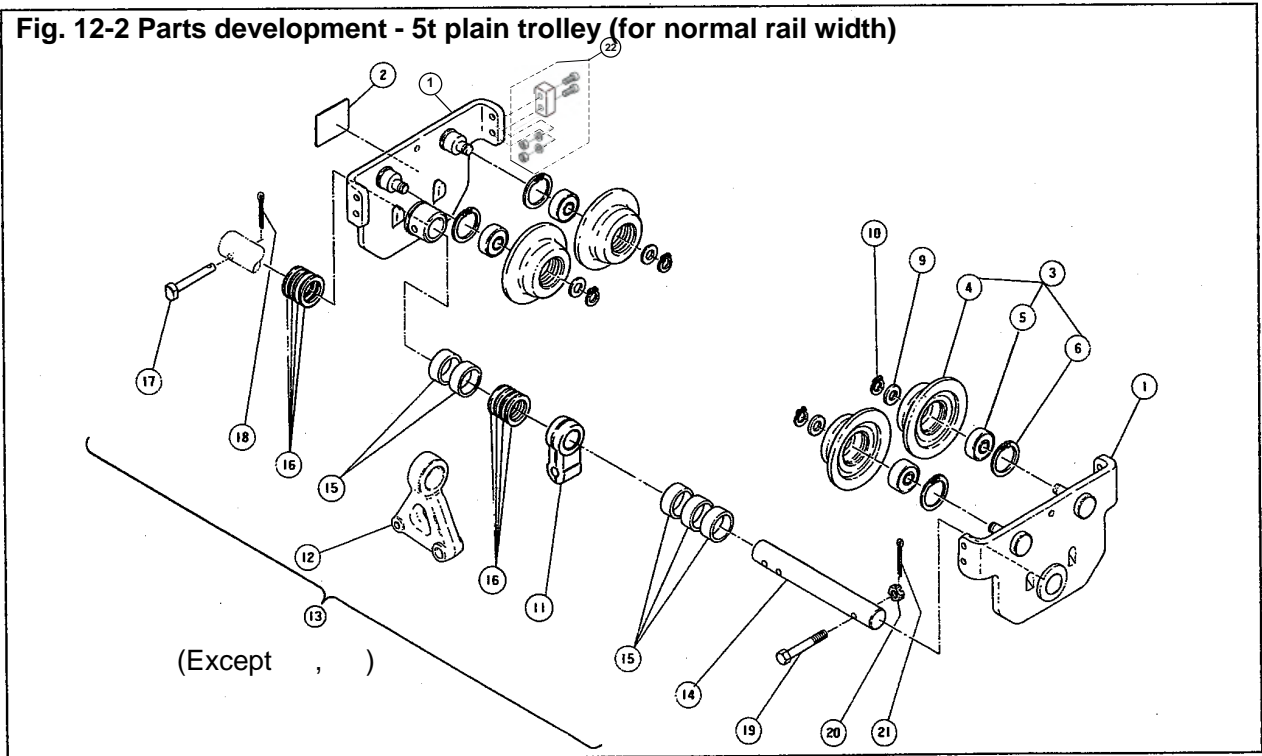

Fig. 12-2 Parts development - 5t plain trolley (for normal rail width)



Plain trolley (Rail width - standard)

Fig. No.	Part No.	Part name	No. per Trolley	WLL (t)					Remarks
				0.5t	1t	2t	3t	5t	
1	5112	Side plate S Assembly	2	T7PA005-5112	T7GA010-5112	T7GA020-5112	T7GA030-5112	T7GA050-5112	
2	800	Name plate B	1	T7PG005-9800 (for 500kg)	T7PG010-9800	T7PG020-9800 (for 2t)	T7PG030-9800 (for 3t)	T7PG050-9800	
				T7PG003-9800 (for 250kg)		T7PG015-9800 (for 1.5t)	T7PG025-9800 (for 2.5t)		
				T7PG001-9800 (for 125kg)		T7PG016-9800 (for 1.6t)	T7PG032-9800 (for 3.2t)		
3	5102	Track wheel S Assembly	4	T6PA 005-5102	T6GA010-5102	T6GA020-5102	T6GA030-5102		
	1102	Track wheel S Assembly	4					T3GA050-1102	
4	102	Track wheel S	4					T3GA050-9102	
5	105	Ball bearing	4					J1GR020-06307	
6	107	Snap ring	4					J1SR000-0080	
7	158	Slotted nut	4	J1NL002-10100					
8	159	Split pin	4	J1PW01-020016					
9	104	Track wheel washer	4		T6GA010-9104	T1GA020-9104	T1GA030-9104	M6SE050S9104	
10	106	Snap ring	4		J1SS000-00015	J1SS000-00020	J1SS000-00025	J1SS000-00035	
11	004	Suspender	1	T7PB005-9004	T7GB010-9004	T7GB020-9004	T7GB020-9004 (for 2.5t) MR2FS9004 (for 3t)	MR1GS9001	for Electric chain hoist (ER2 Series)
12	004	Suspender	1	T7PC005-9004	T7GC010-9004	T7GC020-9004	T7GC030-9004 (for 3t) T7GC025-9004 (for 2.5t)	T5GC050-9004	for Manual chain hoist (M3 Series)
13	1215	Suspension shaft (standard) Assembly	1	T7PD005-1215 (160mm)	T7GD010-1215 (160mm)	T7GD020-1215 (200mm)	T7GD030-1215 (200mm)	T7GD050-1215 (200mm)	
14	215	Suspension shaft (standard)	1	T7PA005-9215 (160mm)	T7GA010-9215 (160mm)	T7GA020-9215 (200mm)	T7GA030-9215 (200mm)	T7GA050-9215 (200mm)	
15	116	Thick spacer		T7PA005-9116	T7GA010-9117	T7GA020-9116	T7GA030-9116	T1GA050-9116	
				8	8	10	12	6	
16	117	Thin spacer		T6PA005-9117	T6GA010-9117	T6GA020-9117	T6GA030-9117		
				13	12	8	15		
	120	Thin spacer	12					M7SS050S9117	
17	156	Shaft stopper pin	2	T6PA005-9156	T6GA010-9156	T6GA020-9156			
							M6FE020S9164	M6SE050S9164	
	159	Shaft stopper pin	1					2	1
18	157	Split pin		J1PW01-032020		J1PW01-040020			
				2		2			
	160	Split pin	1					J1PW02-040022	
19	154	Suspension shaft bolt	1					M6SE050S9161	
20	155	Slotted nut	1					J1NL002-20120	
21	156	Split pin	1					J1PW01-032020	
22	1101	Buffer Assembly	4	T5AB005-1101	T7AB010-1101	T7AB030-1101	T5AB030-1101		

Note: Parts given no part No. are not to be supplied independently.

Geared trolley (Rail width - standard)

Fig. 12-3 Parts development - 3 t and smaller geared trollies

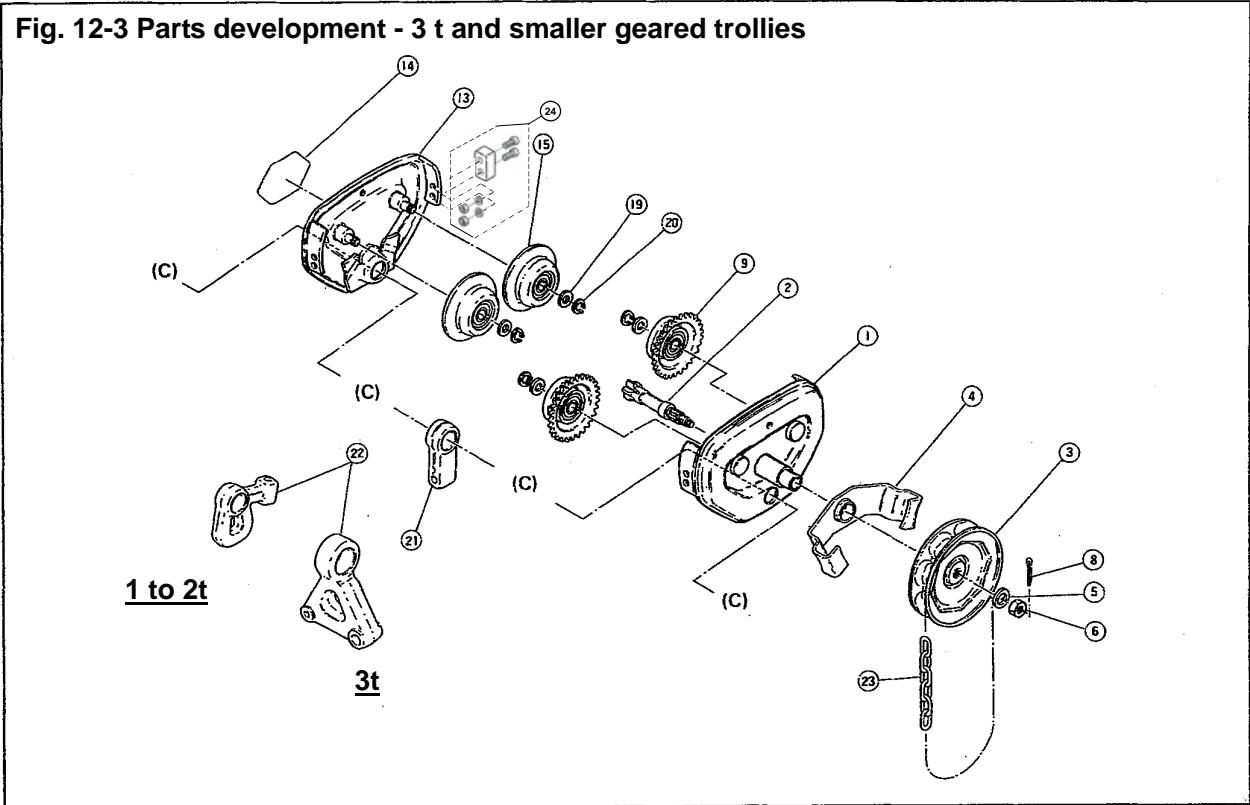
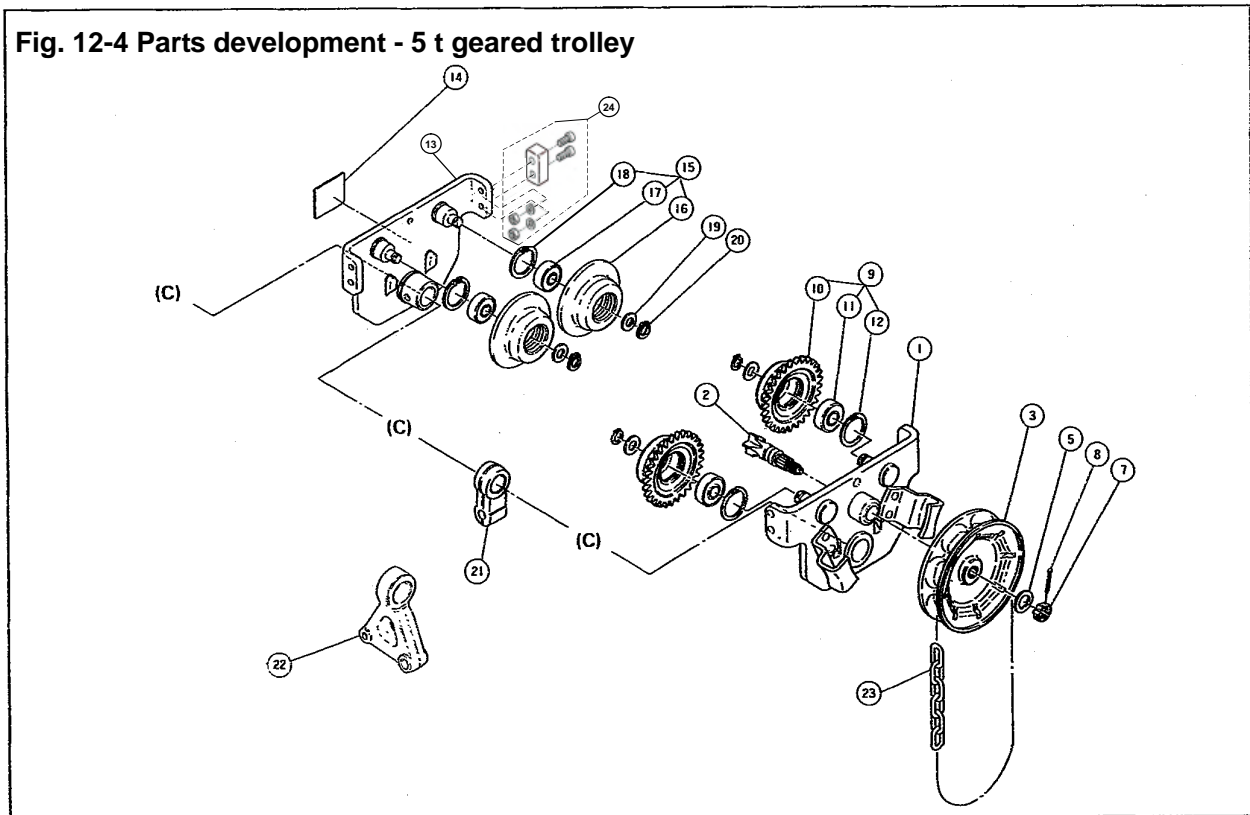

Fig. 12-4 Parts development - 5 t geared trolley



Note: (c) Refer to the parts list of plain trolley for suspender assembly.

Geared trolley (Rail width - standard)

Fig. No.	Part No.	Part name	No. per Trolley	WLL (t)				Remarks
				1t	2t	3t	5t	
1	5111	Side plate G Assembly	1	T7GC010-5111	T7GA020-5111	T7GA030-5111	T5GA050-5511	
2	121	Pinion	1	T7GB010-9121			T4GB010-9121	
	127	Pinion	1	T6GC010-9127				
3	123	Hand wheel	1	T6GA010-9123				
4	5125	Hand chain guide Assembly	1	T6GA010-51251				
5	152	Washer	1	J1WB012-10120			J1WB011-10120	
6	151	Lever nut	1	C2BA400-9074				
7	151	Slotted nut	1				J1NL002-20210	
8	160	Split pin	1	J1PW01-030018			J1PW02-040022	
9	5101	Track wheel G Assembly	2	T6GA010-5101	T6GA020-5101	T6GA030-5101		
	1102	Track wheel G Assembly	2				T3GA050-1101	
10	101	Track wheel G	2				T3GA050-9101	
11	107	Ball bearing	2				J1GR020-06307	
12	105	Snap ring	2				J1SR000-00080	
13	5112	Side plate S Assembly	1	T7GA010-5112	T7GA020-5112	T7GA030-5112	T5GA050-5112	
14	800	Name plate B	1	T7GG010-9800 (for 1t)	T7GG020-9800 (for 2t)	T7GG030-9800 (for 3t)	T7GG050-9800 (for 5t)	
				T7GG005-9800 (for 500kg)	T7GG015-9800 (for 1.5t)	T7GG025-9800 (for 2.5t)		
				T7GG003-9800 (for 250kg)	T7GG016-9800 (for 1.6t)	T7GG032-9800 (for 3.2t)		
				T7GG001-9800 (for 125kg)				
15	5102	Track wheel S Assembly	2	T6GA010-5102	T6GA020-5102	T6GA030-5102		
	1102	Track wheel S Assembly	2				T3GA050-1102	
16	102	Track wheel S	2				T3GA050-9102	
17	107	Ball bearing	2				J1GR020-06307	
18	105	Snap ring	2				J1SR000-00080	
19	104	Track wheel washer	4	T6GA010-9104	T1GA020-9104	T1GA030-9104	M6SE050S9104	
20	106	Snap ring	4	J1SS000-00015	J1SS000-0020	J1SS000-0025	J1S000-00035	
21	004	Suspender	1	T7GB010-9004	T7GB020-9004	T7GB030-9004 (for 2.5t)	MR1GS9001	for Electric chain hoist (ER2 Series)
						MR2FS9004 (for 3t)		
22	004	Suspender	1	T7GC010-9004	T7GC020-9004	T7GC030-9004	T5GC050-9004	for Manual chain hoist (M3 Series)
23	1842	Hand chain	1	C1FA015-1842 (2.5m)	C1FA020-1842 (3m)		C3BA050-1842 (3.5m)	for Manual chain hoist (M3 Series)
					C1FA015-1842 (2m for 1.5t)			

Rail width - option

Fig. 12-6 Suspension shaft W30 assembly. (0.5 t, 3 t)

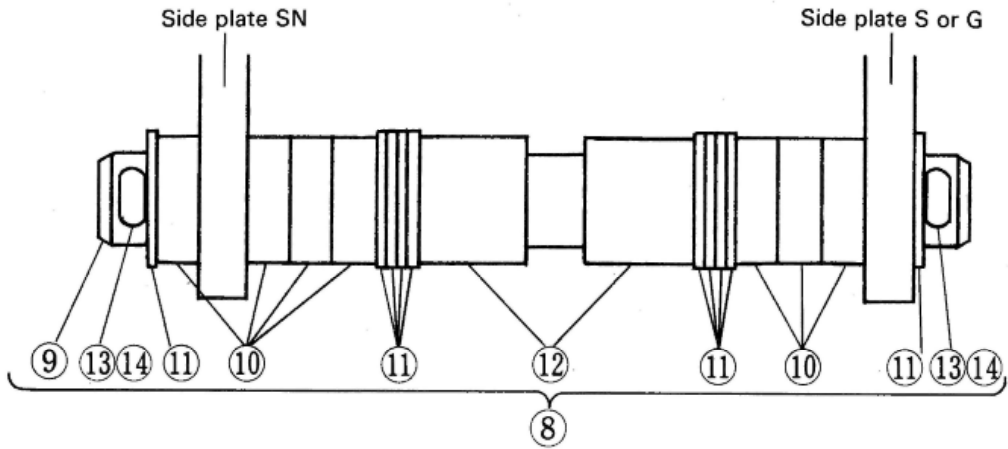
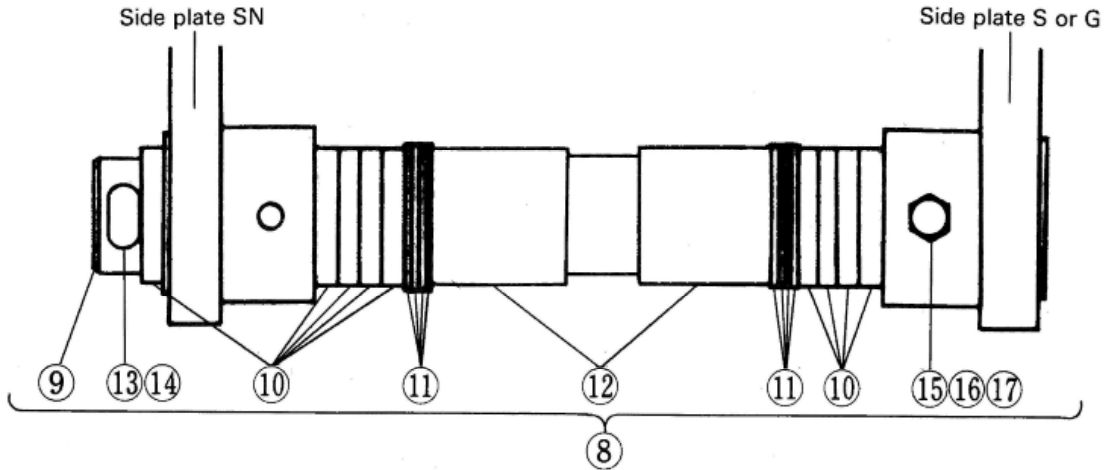

Fig. 12-7 Suspension shaft W30 assembly. (5 t)



Rail width - option

Fig. No.	Part No.	Part name	No. per Trolley	WLL (t)					Remarks
				0.5t	1t	2t	3t	5t	
8	1181	Suspension shaft W300 Assembly	1	T7PD005-1181	T7GD010-1181	T7GD020-1181	T7GD030-1181	T7GD050-1181	
9	181	Suspension shaft W300	1	T7PA005-9181	T7GA010-9181	T7GA020-9181	T7GA030-9181	T7GA050-9181	
10	116	Thick spacer		T7PA005-9116	T7GA010-9116	T7GA020-9116	T7GA030-9116	T1GA050-9116	
				7	7	11	11	9	
11	117	Thin spacer	10	T7PA005-9117	T6GA010-9117	T6GA020-9117	T6GA030-9117	—————	
	120	Thin spacer	8	—————	—————	—————	—————	M7SS050S9117	
12	182	Fixing spacer W300	2	T7PA005-9182	T7GA010-9182	T7GA020-9182	T7GA030-9182	T7GA050-9182	
13	156	Shaft stopper pin	2	T6PA005-9156	T6GA010-9156	T6GA020-9156	M6FE020S9164	—————	
		Split pin	1	—————	—————	—————	—————	J1PW01-030022	
14	157	Split pin	2	J1PW01-032020		J1PW01-040020			
15	154	Suspension shaft bolt	1	—————	—————	—————	—————	M6SE050S9161	
16	155	Slotted nut	1	—————	—————	—————	—————	J1NL002-20120	
17	159	Shaft stopper pin	1	—————	—————	—————	—————	M6SE050S9164	
18	160	Split pin	1	—————	—————	—————	—————	J1PW02-040022	

12. CONTENTS OF EC DECLARATION OF CONFORMITY

We, **KITO Corporation**,
2000 Tsuijjarai, Showa-cho,
Nakakoma-gun, Yamanashi, [409-3853](#), Japan
declare under our sole responsibility that the products:

Plain trolley TSP / Geared trolley TSG, **model TS2**
in capacity range of 500 kg up to 5 tonnes

Geared trolley TSG, **model TS1**
in capacity range of 7.5 tonnes to 30 tonnes,

to which this declaration relates is in conformity with the following EC directives and standards.

EC directives:

Machinery Directive **2006/42/EC**

Harmonized standards:

EN ISO 12100:2010 **Safety of machinery**

EN 818-7:2002+A1:2008 **Short link chain for lifting purposes,
increased quality, grade V, certified by
Fachausschuss Metall und Oberflächenbehandlung**

EN 13157:2004+A1:2009 **Hand powered lifting equipment,
except for the requirement of "5.2.6 Operating effort"**

Authorized representative for the arrangement of the technical documents:

Udo Kleinevoß

Technical Manager

Kito Europe GmbH. 40549 Düsseldorf

KITO

URL. <http://www.kito.co.jp>

KITO Europe GmbH

Heerdter Lohweg 93, D-40549 Düsseldorf, Germany

TEL: +49-(0)211-528009-00

FAX: +49-(0)211-528009-59

E-mail: info@kito-europe.eu

URL: <http://www.kito.net/>

KITO corporation

Tokyo Head office:

SHINJUKU NS Building 9F, 2-4-1, Nishi-Shinjuku, Shinjuku-ku, Tokyo 163-0809, Japan

URL: <http://www.kito.com/>

Head office & Factory:

2000 Tsuijjarai Showa-Cho, Nakakoma-Gun, Yamanashi 409-3853, Japan

URL: <http://www.kito.com/>