

Original Instruction

Supplement Manual

**OWNER'S (OPERATOR'S) MANUAL
AND SAFETY INSTRUCTIONS
FOR KITO GEARED TROLLEY**

TS SERIES (Model **TSB**)

For WLL 7.5t to 30t

This supplement Manual includes information only for larger WLL trolleys.

ALWAYS use this Manual in combination with the original Manual ("OWNER'S (OPERATOR'S) MANUAL AND SAFETY INSTRUCTIONS (Bulletin NO. OM-TSZZZZ-CEE-01)").

ALWAYS SAVE THIS BOOK FOR FUTURE REFERENCE.

KITO

Issued January 2010. Revised May, 2016(revision 05)

CONTENTS

Remarks : (1) Information written in bold letters is included in this manual.

(2) For information marked with a **▲**, refer to the “OWNER’S (OPERATOR’S) MANUAL AND SAFETY INSTRUCTIONS (OM-TSZZZZ-CEE-01).”

1.	DEFINITIONS	
2.	INTENDED PURPOSE	
3.	BEFORE USE	
3.1	Safety summary	
3.2	Safety instructions	
4.	MAIN SPECIFICATION	1
5.	INSTALLATION	2
5.1	Coupling with M3 series manual chain hoists	2
5.2	Coupling with ES or ER series electric chain hoists	3
5.3	Adjusting trolley width before installation	5
5.4	Installation of trolley onto beam	6
5.5	Installation of stopper onto traversing beam	
5.6	Check points after installation	
6.	OPERATION	
6.1	Intended purpose of trolley operation	
6.2	Safety working environment	
6.3	Operation	
6.4	Trolley storage	
7.	INSPECTION	
7.1	Outline	
7.2	Daily inspection	
7.3	Periodic inspection	8
8.	MAINTENANCE	
8.1	Lubrication	
8.2	Overhaul and assembly	9
9.	OPTIONAL BUFFER	
9.1	Buffer	
10.	CONFORMITY DECLARATION	
11.	WARRANTY	
12.	PARTS LIST	12

4. MAIN SPECIFICATIONS

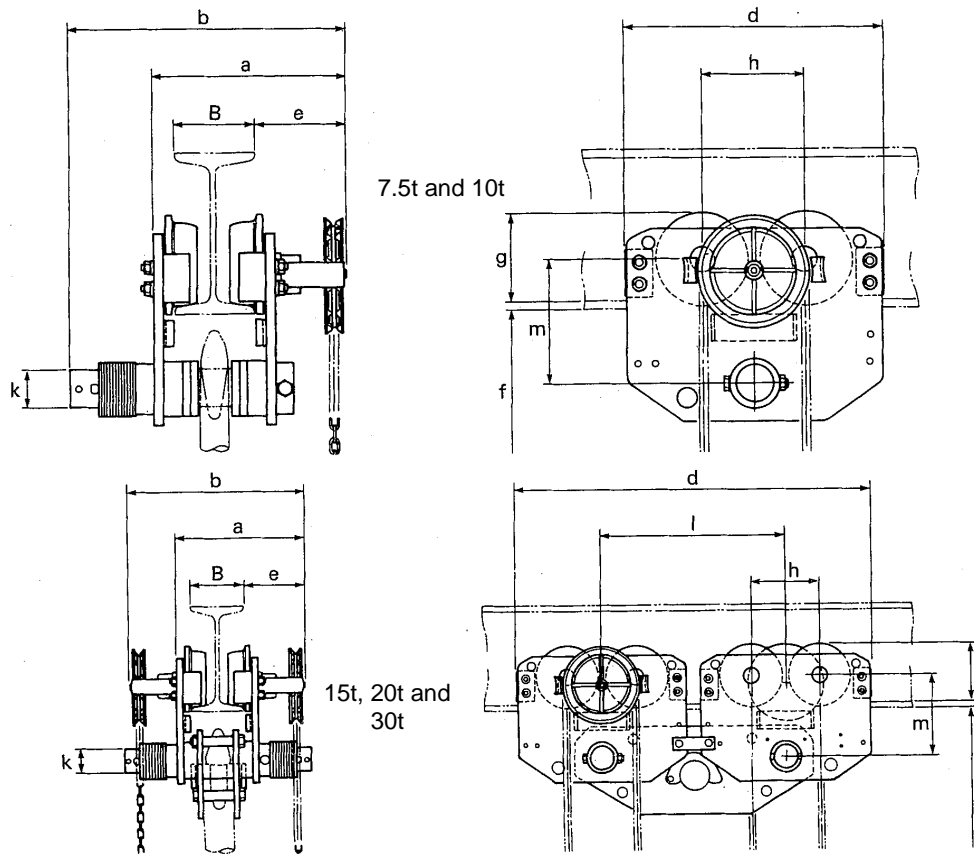

Code		WLL (t)	Rail width range B (mm)		Minimum radius for curve (mm)	Net weight (kg)		Hand chain folded length (m)		a max. (mm)	
M3 combined (C)	ES combined (E)		Standard	Option W30		(C)	(E)	(C)	(E)	(C)	(E)
TSG075C	TSG075E	7.5	150 to 220	221 to 305	3000	112	121	4.0	3.5	439	549
TSG100C	TSG100E	10			3000	112	116	4.0	3.5	439	549
TSG150C	TSG150E	15			∞	265	235	4.5	4.0	439	549
TSG200C	TSG200E	20			∞	265	235	4.5	4.0	439	549
TSG300C	—	30	175, 190	—	∞	470	—	5.0	—	543	—

Code		WLL (t)	b (mm)		d (mm)	e (mm)		f (m)		g (mm)	h (mm)	k (mm)	l (mm)	m (mm)
(C)	(E)		(C)	(E)		(C)	(E)	(C)	(E)					
TSG075C	TSG075E	7.5	523	633	492	178	288	3.7	3.2	170	196.5	$\phi 70$	—	230
TSG100C	TSG100E	10	523	633	492	178	288	3.7	3.2	170	196.5	$\phi 70$	—	230
TSG150C	TSG150E	15	576	796	1012	178	288	4.2	3.7	170	196.5	$\phi 70$	520	230
TSG200C	TSG200E	20	576	796	1012	178	288	4.2	3.7	170	196.5	$\phi 70$	520	230
TSG300C	—	30	790	—	1160	300	—	4.7	—	197	233	$\phi 70$	600	235

- Remarks :
- (1) The maximum 300mm rail width are available as option. (W30 range)
 - (2) Net weight is when flange width is in standard.
 - (3) Dimension "a" is when flange width is adjusted to the maximum of the standard range.
 - (4) Dimension "b" is when flange width is in standard range.
 - (5) Dimension "f" is hand chain in folded.

Allowable ambient conditions;

Operation temperature: -20°C to +60°C: (-20°C to + 40°C for the use with an electric chain hoist)

Operation humidity: up to 100%

Note:

- Install the trolley at the level an operator is able to operate the hand chain on the ground.
- If the adjustment of the bottom at the hand chain between 500mm and 1000mm from the ground is required, consult KITO.
- The rail that the trolley to be installed on should not have deflection exceeding 1/800 the span and/or longitudinal slope of the traveling surface exceeding 0.25%.

5. INSTALLATION

5.1 Coupling with M3 series manual chain hoists

- (1) This series of the geared trolley covers from 7.5t to 30t WLL and allows to couple with the same range of M3 series manual chain hoist.
- (2) The coupling is realized by a manner where a suspension shaft of a trolley suspends a top hook of a hoist directly.
- (3) In cases of 7.5t and 10t couplings, the top hook of a hoist is suspended by single suspension shaft connecting a couple of side plates as illustrated in the previous section of main specification.
And in cases of 15t, 20t and 30t couplings, the top hook of a hoist is suspended by a particular suspension shaft which is connected to two pairs of side plates through a couple of suspension plates as illustrated below Fig. 5-1.
- (4) See section 5.3 to adjust the trolley width to an expected rail width, and see section 5.4 to install the trolley onto the traversing rail.

Fig. 5-1 Connecting M3 hoist to TSG trolley (Example of 15t, 20t and 30t)

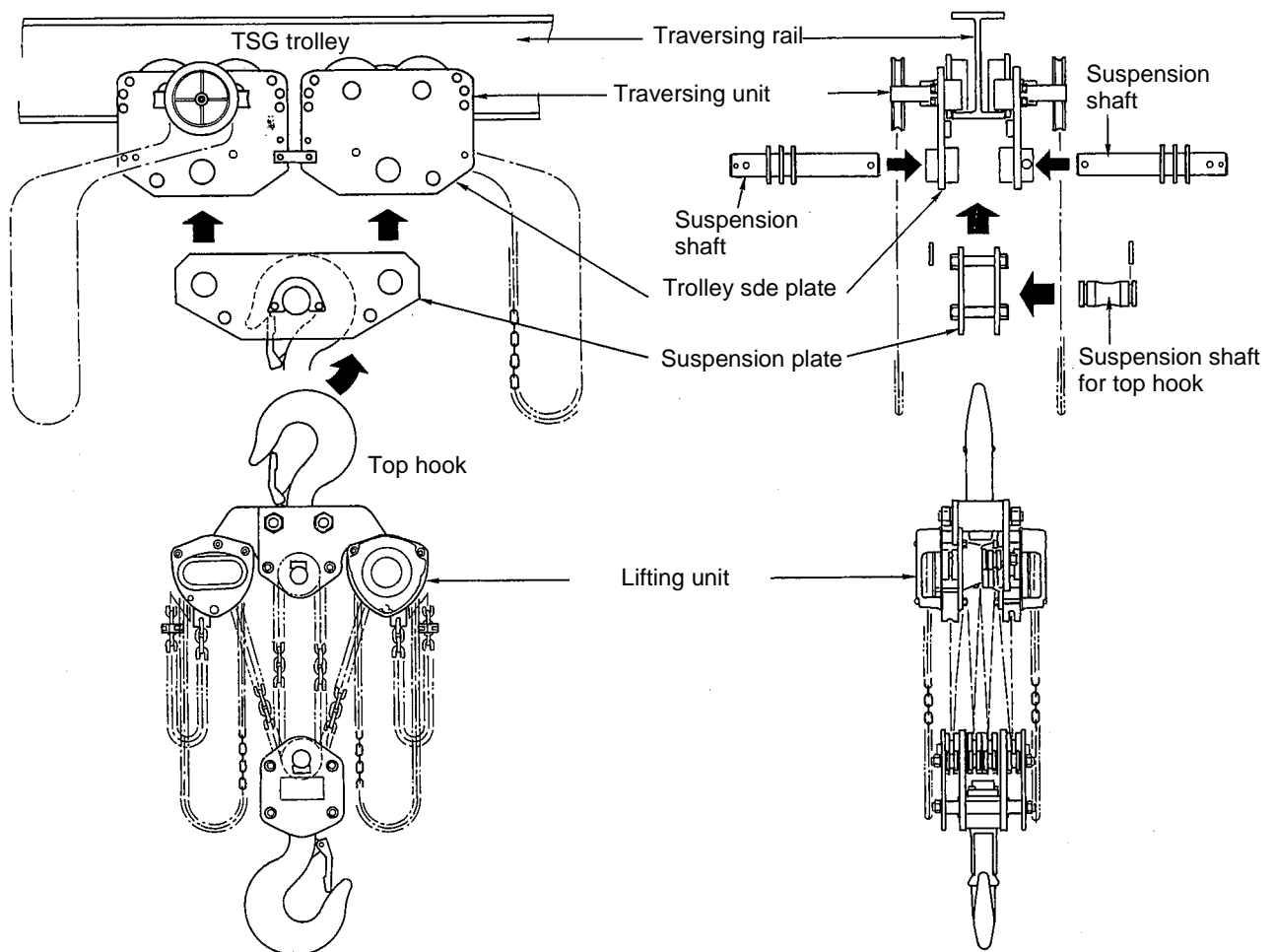

5.2 Coupling with ES, ER series electric chain hoists

- (1) This series of the geared trolley covers from 7.5t to 20t WLL and allow to couple with the same range of ES, ER series electric chain hoist.
- (2) The coupling is realized by means of not a top hook like M3 but a couple of top suspension plates which is to be connected to trolley side plates by suspension shaft.
- (3) In case of 7.5t and 10t couplings, an electric chain hoist consisting of a pair of lifting units is suspended by single suspension shaft because a trolley consists of a couple of side plates.
And in cases of 15t and 20t couplings, an electric chain hoist also consisting of a pair of lifting units is suspended by a couple of suspension shafts because a trolley consists of two couples of side plates as illustrated below Fig. 5-2 or Fig. 5-3.
- (4) See section 5.3 to adjust the trolley to harmonize with an expected rail width, and see section 5.4 to install the trolley on to the traversing rail.

Fig.5-2 Connecting ES hoist to TSG trolley (Example of 15t or 20t)

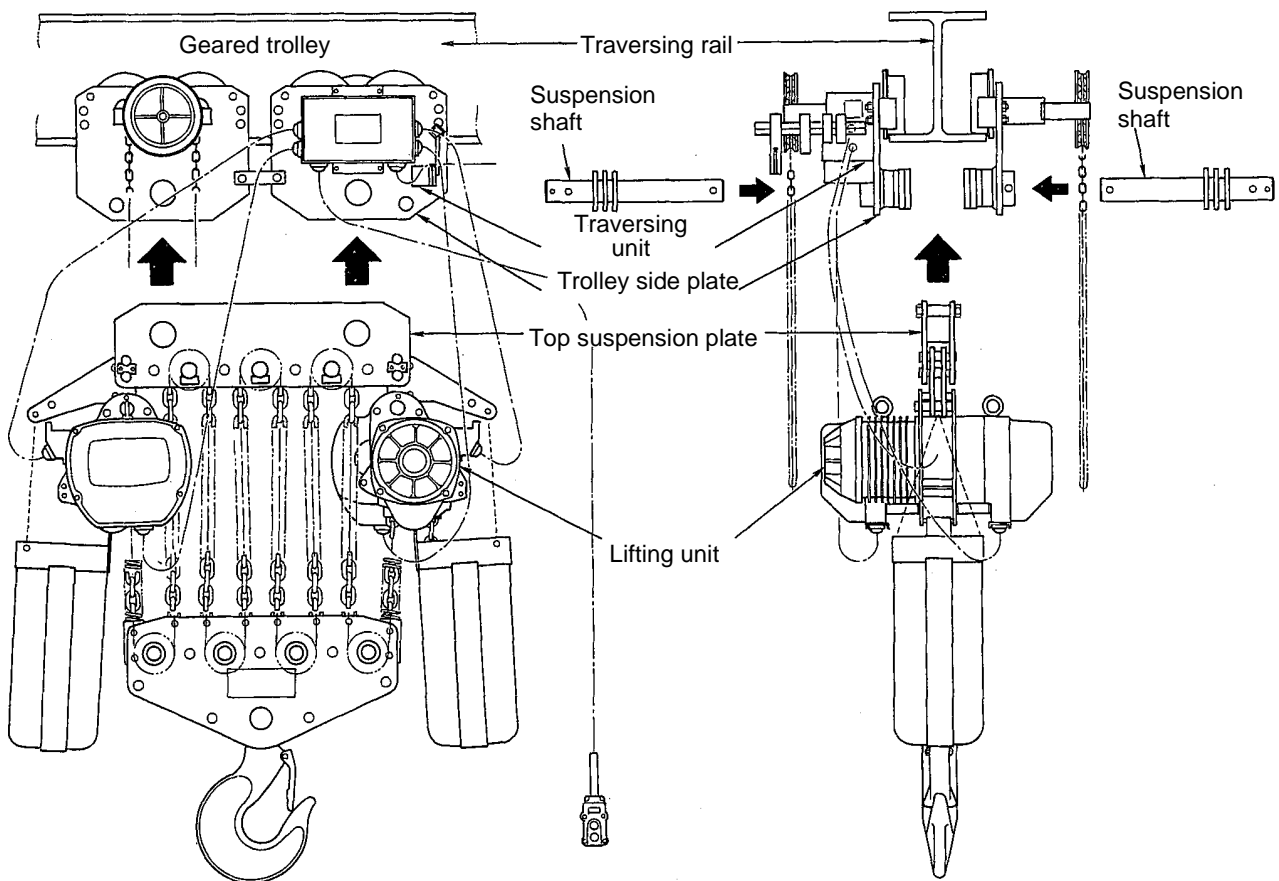
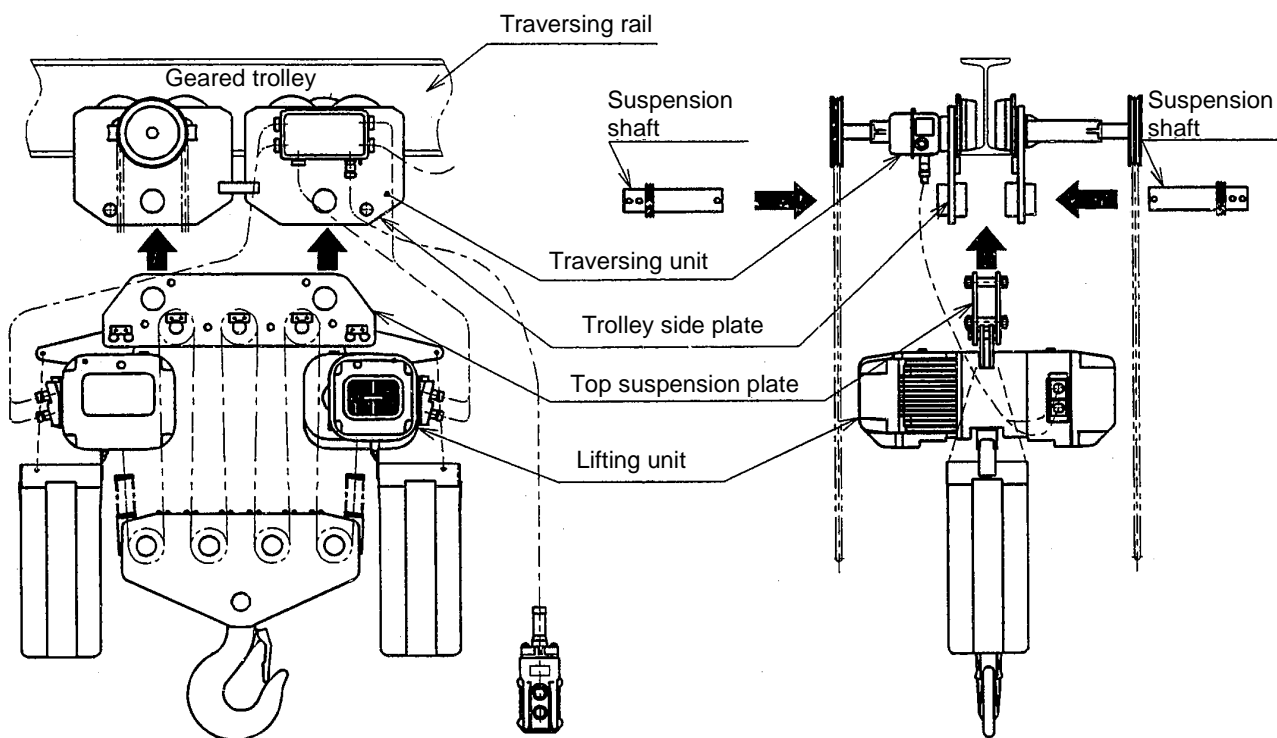

Fig. 5-3 Connecting ER hoist to TSG trolley (Example of 15t or 20t)



5.3 Adjustment of trolley width before installation

Before installation, **NEVER** fail to make the following adjustment for a proper clearance between the traversing rail flange and track wheel flange.

5.3.1 Adjusting “A”

When the side plates S and G are spread fully outside, the proper distance between them should be so that the dimension “A” becomes approximately 4mm wider than the dimension “B”. (See figure below.)

Make adjustment by adding or subtracting the inner or outer spacers irrespective of the numbers tabulated in Table 5-1.

5.3.2 Adjusting spacers arrangement

The Table 5-1 has been prepared for the purpose to inform proper arrangement of adjusting spacers consisting of thin, thick and fixing spacers to applicable range and considerable size of traversing rail. .

5.3.3 Note on 15t, 20t and 30t trolleys

Because two traversing units are combined in a 15t, 20t and 30t trolley, **NEVER** fail to adjust both units correctly in the same way.

⚠ WARNING

ALWAYS insert securely the split pin into the shaft stopper pin to avoid coming off the suspension shaft.

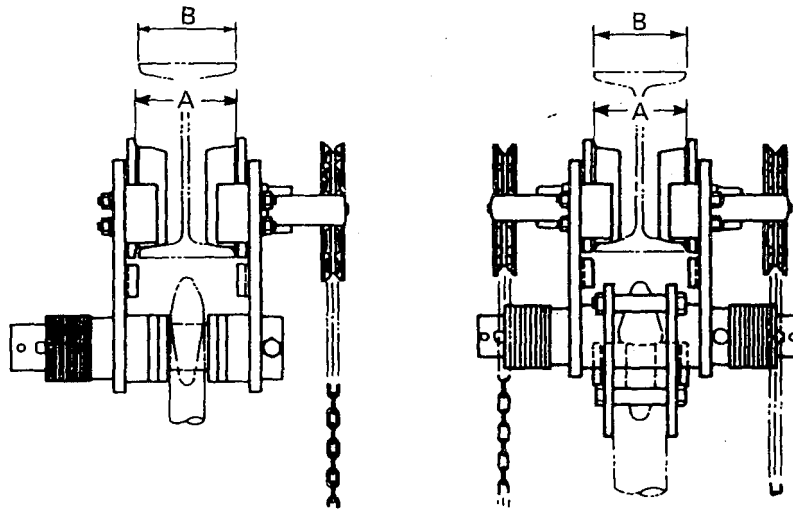

Note; Either trolley to be mounted on tapered flange rail or trolley to be mounted on flat flange rail is available. However unless otherwise mentioned, the tapered type will be shipped. If the flat flange type is preferable for you, specify in advance.

* For either type, the dedicated wheel must be used.

Flat flange wheel	Tapered flange wheel

Table 5-1 Adjusting spacers arrangement on suspension shaft

WLL (T)		Beam flange width (mm)		Number of adjusting spacers																														
		149 150	153	155	160	163	170	175	178	180 181	184 185	200	203	215	220	229	232	250	254	257	260	264	267	279	283	286	289	295	298	300	302	305		
7.5	Thin spacer	Inner	1+1	1+2	1+2	2+3	3+3	4+4	1+1	1+2	2+2	2+3	1+1	1+2	3+3	4+4	1+1	1+2	4+4	1+1	5+1	5+2	2+3	3+3	1+1	1+2	2+2	2+3	3+0	4+0	4+0	4+1	5+1	
		Outer	6	5	5	3	2	0	6	5	4	3	6	5	2	0	6	5	0	6	2	1	3	2	6	5	4	3	5	4	4	3	2	
	Thick spacer	Inner	2+2	2+2	2+2	2+2	2+2	2+2	3+3	3+3	3+3	3+3	4+4	4+4	4+4	4+4	2+2	2+2	2+2	3+3	2+3	2+3	3+3	3+3	4+4	4+4	4+4	4+4	4+5	4+5	4+5	4+5	4+5	4+5
		Outer	4	4	4	4	4	4	2	2	2	2	0	0	0	0	5	5	5	3	4	4	3	3	1	1	1	1	0	0	0	0	0	
	Fixing spacer	Inner															2	2	2	2	2	2	2	2	2	2	2	2	2	2	2	2	2	
	15	Thin spacer	Inner	0	1+0	1+1	1+2	2+2	3+3	0	1+0	1+1	1+2	4+0	4+1	6+2	7+3	1+1	1+2	4+4	1+1	1+2	2+2	2+3	3+3	1+1	1+2	2+2	2+3	3+4	4+4	4+0	4+1	5+1
Outer			10	9	8	7	6	4	10	9	8	7	6	5	2	0	6	5	0	6	5	4	3	2	6	5	4	3	1	0	4	3	2	
Thick spacer		Inner	0	0	0	0	0	0	1+1	1+1	1+1	1+1	1+2	1+2	1+2	1+2	3+3	3+3	3+3	4+4	4+4	4+4	4+4	4+4	5+5	5+5	5+5	5+5	5+5	5+5	5+6	5+6	5+6	
		Outer	3	3	3	3	3	3	1	1	1	1	0	0	0	0	5	5	5	3	3	3	3	3	1	1	1	1	1	0	0	0		
Fixing spacer		Inner																																

30		175	190
	Inner	0	1+1
	Outer	2	0

Note: 1) Take note the numbers on spacers of inner side as follows.

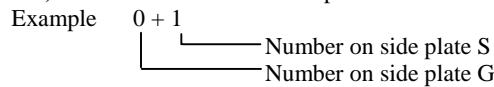

2) Adjustment of trolley width

Refer to 5.3 on page 5.

Adjustment the dimensions by appropriately increasing or decreasing the number of inner or outer adjusting spacers, without strictly adhering to the number of adjusting spacers shown in the above table.

5.4 Installing trolley onto traversing rail

5.4.1 Installing from the rail end

In case that the trolley can be installed by entering from the rail end as completed condition coupled with a hoist;

- (1) remove the stopper at the end of the rail,
- (2) enter the completed (having adjusted to meet the rail width and assembled) trolley from the rail end along the rail flange, and
- (3) fix the stopper to the rail end surely.

5.4.2 Installing separately

In case that the trolley can not be installed by entering from the rail end, install it separately by dividing into side plate S, side plate G and hoist unit as the following Fig. 5-5 or Fig. 5-6.

⚠ DANGER

NEVER try to separate a trolley side plates S and G if it is coupled with a hoist when they are suspended on the rail for installation.

- (1) Separate the hoist from the trolley, if they are coupled.
- (2) Mount the trolley onto the rail;
 - (a) remove the shaft stopper pin from the suspension shaft, and remove the side plate S, spacers and top hook or suspension plate,
 - (b) mount the track wheels of the side plate G onto the rail flange,
 - (c) assemble the spacers, top hook or suspension plate, other spacers and side plate S onto the suspension shaft,
 - (d) push in the side plate S with mounting the track wheels onto the other side of the rail flange,
 - (e) insert the shaft stopper pin into the suspension shaft securing it with a split pin,
 - (f) bend correctly both branches of the split pin after insert, and
 - (g) connect the hoist to the trolley.

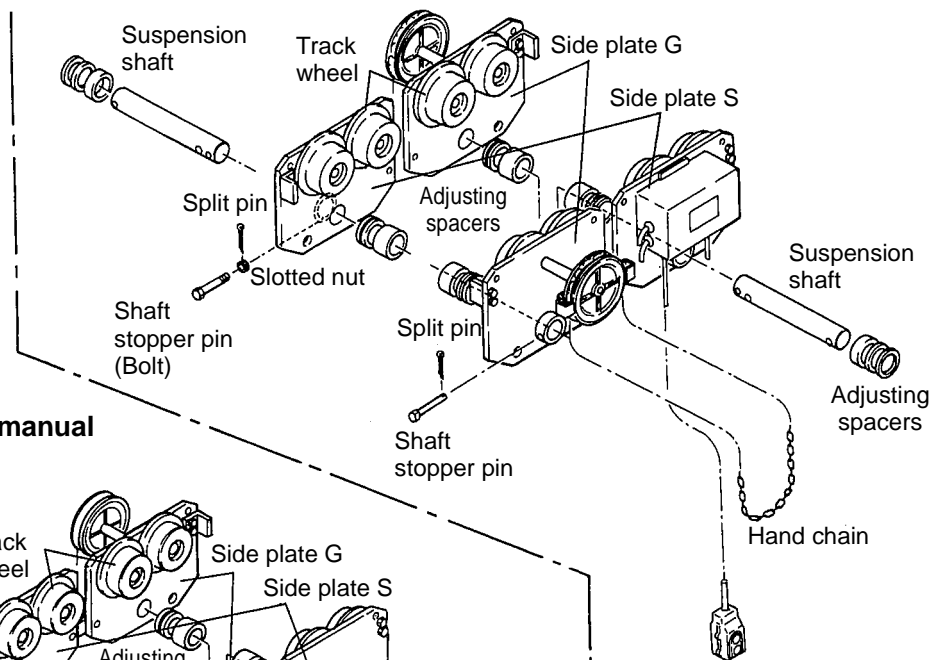

Fig. 5-5 TSG trolley for M3 manual chain hoist

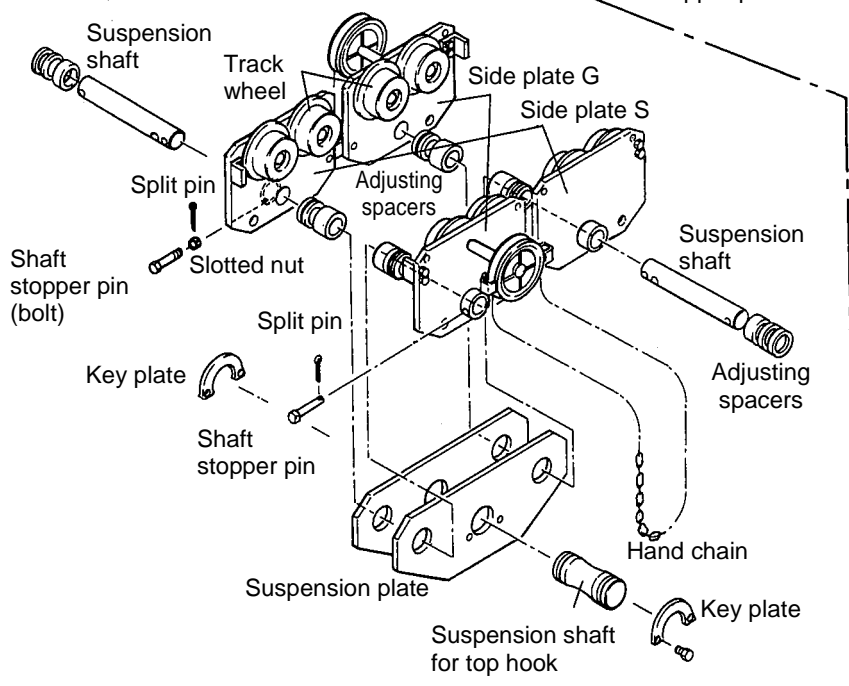

Fig. 5-6 TSG trolley for ES electric chain hoist

7.3 Periodic inspection

Item	Inspection method	Discard limit/criteria	Remedy																																												
2. Side plate deformation	Check with calipers.	The difference of dimension "A" and "B" should not exceed 2mm.	If the difference exceeds 2mm, replace it with a new one.																																												
3. Track wheel wear	Check visually or use calipers as needed.	Wear of flange tread should not be less than the limits on the table below.	Replace it with a new one if it is less than the limit.																																												
	<table border="1"> <thead> <tr> <th rowspan="2">Track wheel</th> <th rowspan="2">WLL (t)</th> <th colspan="2">Tread diameter: D (mm)</th> <th colspan="2">Flange thickness: t (mm)</th> </tr> <tr> <th>Standard</th> <th>Limit</th> <th>Standard</th> <th>Limit</th> </tr> </thead> <tbody> <tr> <td rowspan="2">For tapered rail flange</td> <td>7.5</td> <td rowspan="2">φ155</td> <td rowspan="2">φ148</td> <td rowspan="2">13</td> <td rowspan="2">9</td> </tr> <tr> <td>10</td> </tr> <tr> <td rowspan="2"></td> <td>15</td> <td rowspan="2">φ175</td> <td rowspan="2">φ167</td> <td rowspan="2">22</td> <td rowspan="2">15</td> </tr> <tr> <td>20</td> </tr> <tr> <td>For flat rail flange</td> <td>7.5</td> <td rowspan="2">φ147</td> <td rowspan="2">φ140</td> <td rowspan="2">13</td> <td rowspan="2">9</td> </tr> <tr> <td></td> <td>10</td> </tr> <tr> <td></td> <td>15</td> <td></td> <td></td> <td></td> <td></td> </tr> <tr> <td></td> <td>20</td> <td></td> <td></td> <td></td> <td></td> </tr> </tbody> </table>			Track wheel	WLL (t)	Tread diameter: D (mm)		Flange thickness: t (mm)		Standard	Limit	Standard	Limit	For tapered rail flange	7.5	φ155	φ148	13	9	10		15	φ175	φ167	22	15	20	For flat rail flange	7.5	φ147	φ140	13	9		10		15						20				
Track wheel	WLL (t)	Tread diameter: D (mm)				Flange thickness: t (mm)																																									
		Standard	Limit	Standard	Limit																																										
For tapered rail flange	7.5	φ155	φ148	13	9																																										
	10																																														
	15	φ175	φ167	22	15																																										
	20																																														
For flat rail flange	7.5	φ147	φ140	13	9																																										
	10																																														
	15																																														
	20																																														
Track wheel for tapered rail flange																																															
Track wheel for flat rail flange																																															

8.2 Overhaul and assembly

Overhaul and assembly should be performed with reference to the following Fig. 8-1 or 8-3

Fig. 8-1 Trolley parts arrangement for M3 hoist

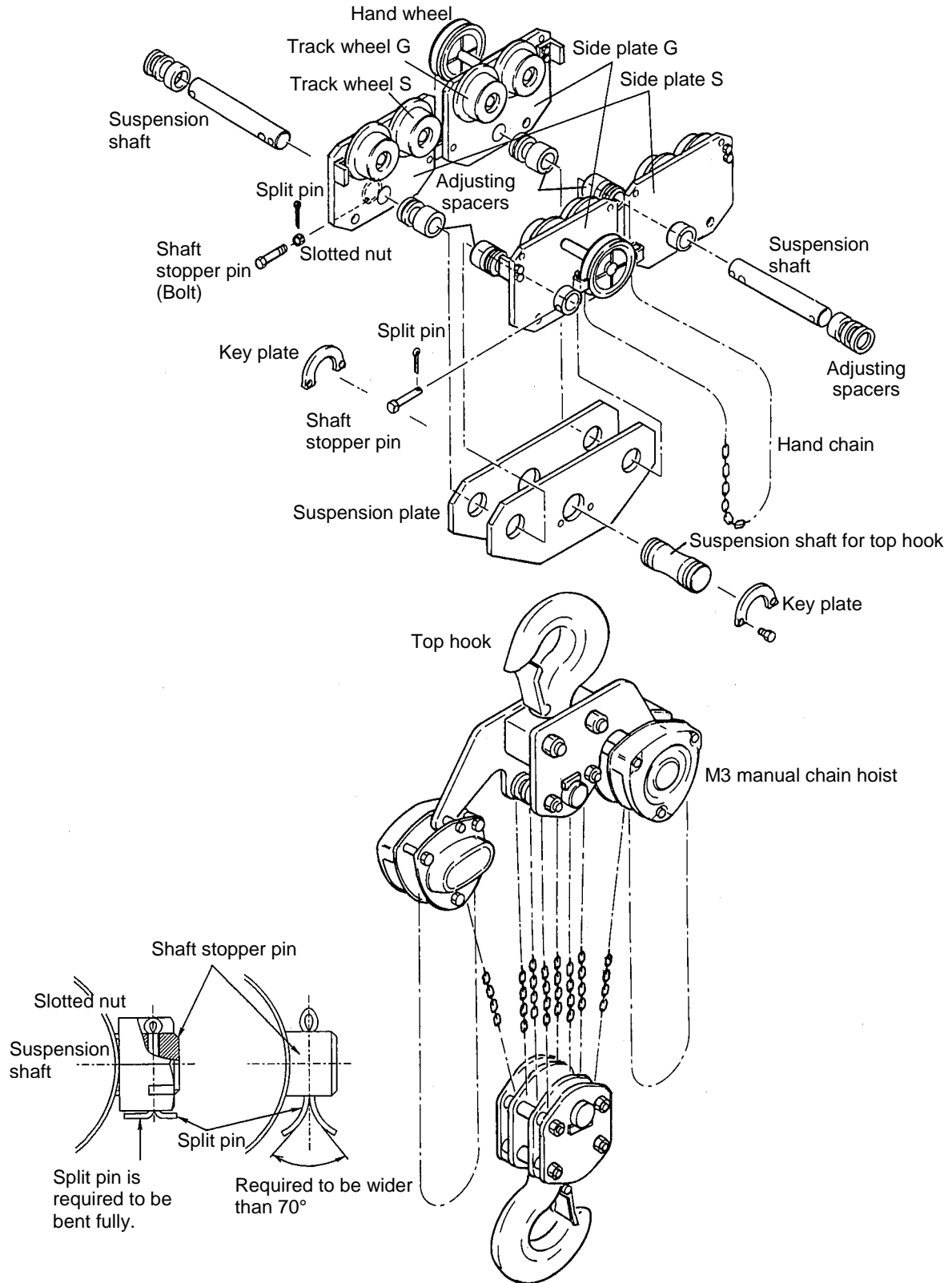

Fig. 8-2 Trolley parts arrangement for ES hoist

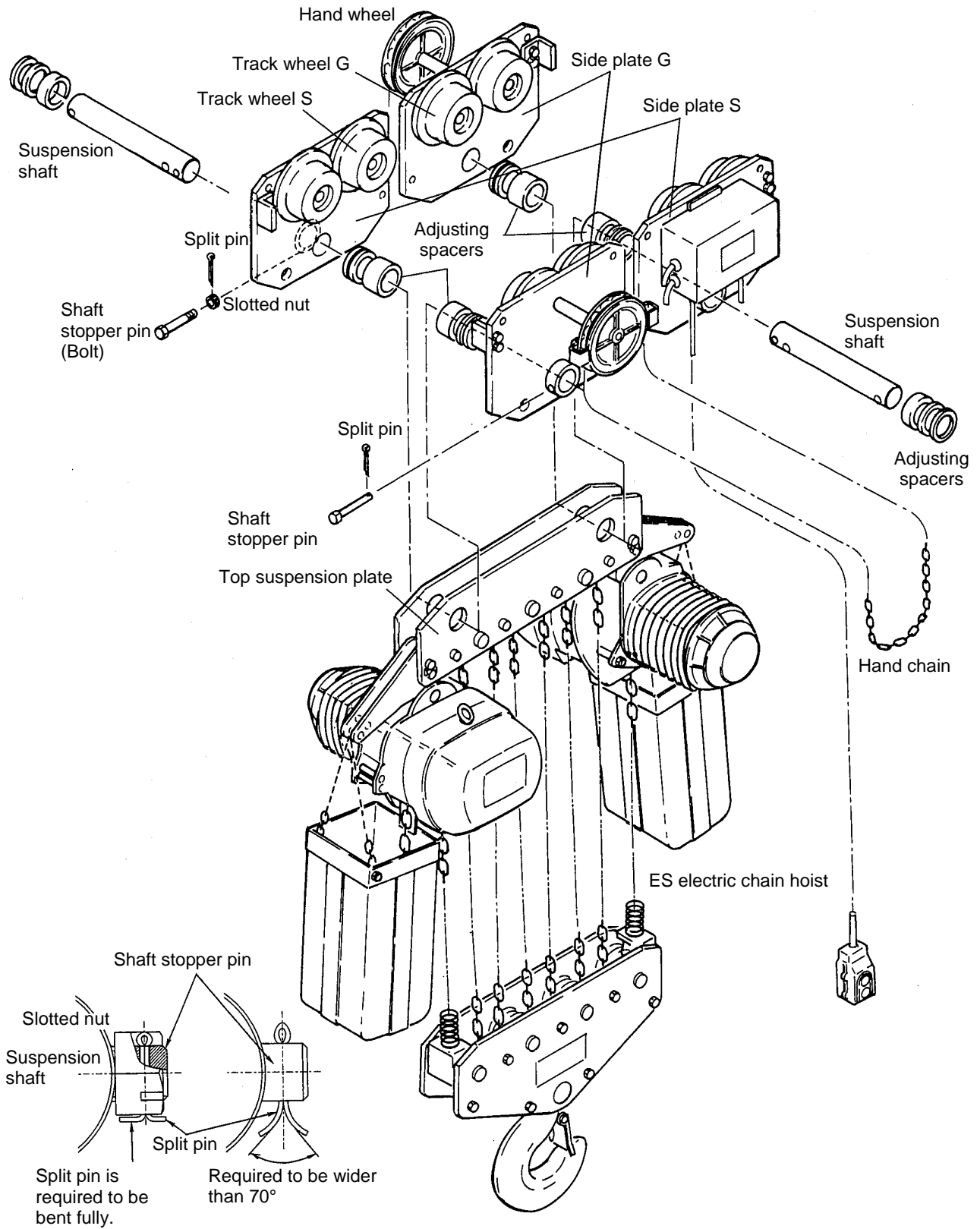
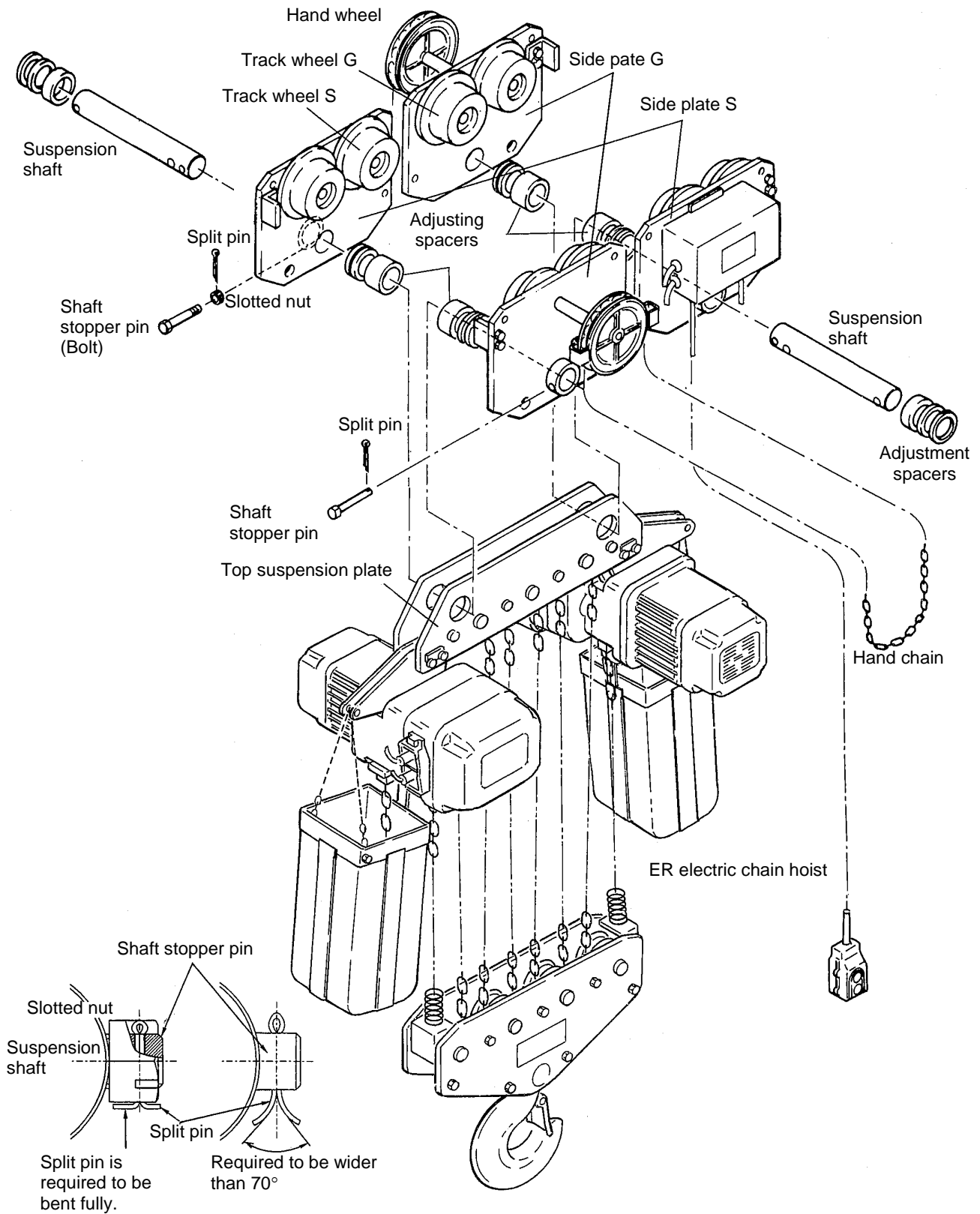

Fig. 8-3 Trolley parts arrangement for ER hoist



12. PARTS LIST

When ordering replacement parts, please specify WLL, No., part name and quantity.

Fig. 12-1 Parts development - TSG trolley for M3 hoist

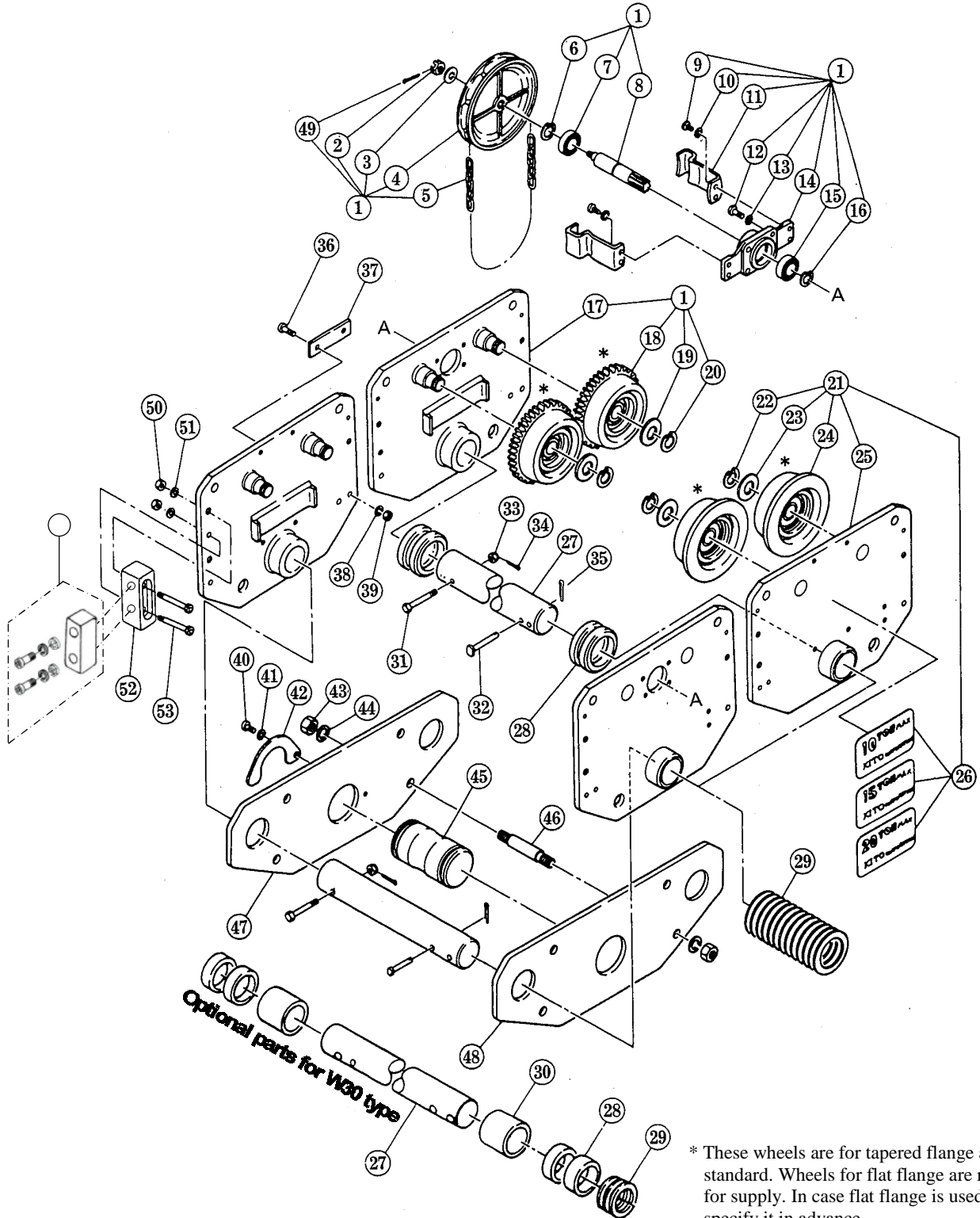

Fig. No.	Part No.	Part name	Nos per Trolley			Capacity		
			7.5t, 10t	15t	20t	7.5t, 10t	15t	20t
1		Side plate G complete set	1	2				
2	T3G151	Slotted nut	1	2				
3	T3G152	Washer	1	2				
4	T3G123	Hand wheel	1	2				
5	CF842	Hand chain	1	2				
6	T3G132	Snap ring	2	4				
7	T3G131	Ball bearing	2	4				
8	T3G127	Pinion	1	2				
9	T3G163	Socket bolt	4	8				
10	E6F854	Spring washer	4	8				
11	T3G125	Hand chain guide	2	4				
12	M6F575	Socket bolt	4	8				
13	M6F576	Spring washer	4	8				
14	T3G128	Pinion holder	1	2				
15	T3G131	Ball bearing	2	4				
16	T3G132	Snap ring	2	4				
17		Side plate G assembly	1	2				
18	T3G1101	Track wheel G assembly	1B*	2B*				
	T3G1108		1Z*	2Z*				
19	T3G104	Washer	4	8				
20	T3G106	Snap ring	4	8				
21		Side plate S complete set	1	2				
22	T3G106	Snap ring	4	8				
23	T3G104	Washer	4	8				
24	T3G1102	Track wheel S assembly	2B*	4B*				
	T3G1109		2Z*	4Z*				
25		Side plate S assembly	1	2				
26	T3G801	Name plate B	1	1				
27	MS115	Suspension shaft	1	2				
	MS181		1 [W]	2 [W]				
28	MS117	Thick spacer	See table 5-1 in page 6.					
29	MS118	Thick spacer						
30	MS182	Fixing spacer	2 [W]					
31	MS161	Bolt	1	2				
32	MS164	Shaft stopper pin	1	2				
33	T3G154	Slotted nut	1	2				
34	T3G155	Split pin	1	2				
35	T3G157	Split pin	1	2				
36	MS106	Bolt		4				
37	MS105	Connection plate		2				
38	MS174	Spring washer		4				
39	MS173	Nut		4				
40	T3G168	Bolt		1				
41	E6F854	Spring washer		1				
42	T3G145	Key plate		1				
43	E6S081	Nut		8				
44	E6S082	Spring washer		8				
45	T3G144	Suspension shaft		1				
46	T3G143	Stay bolt		4				
47	T3G141	Suspension plate A		1				
48	T3G142	Suspension plate B		1				
49	T3G160	Split pin	1	2				
50	T5G144	Nut	8	8				
51	T5G143	Spring washer	8	8				
52	T5G141	Bumper	4	4				
53	T5G142	Socket bolt	8	8				
54	T5AB-1101	Buffer assembly	4	4				

Note : [W] indicates wide flange type.

: The parts given no part number in the above table can not be supplied.

* : Symbol Z means track wheel applied to flat flange rail; Symbol B to tapered flange rail.

Fig. 12-2 Parts development - TSG trolley for ES or ER hoist

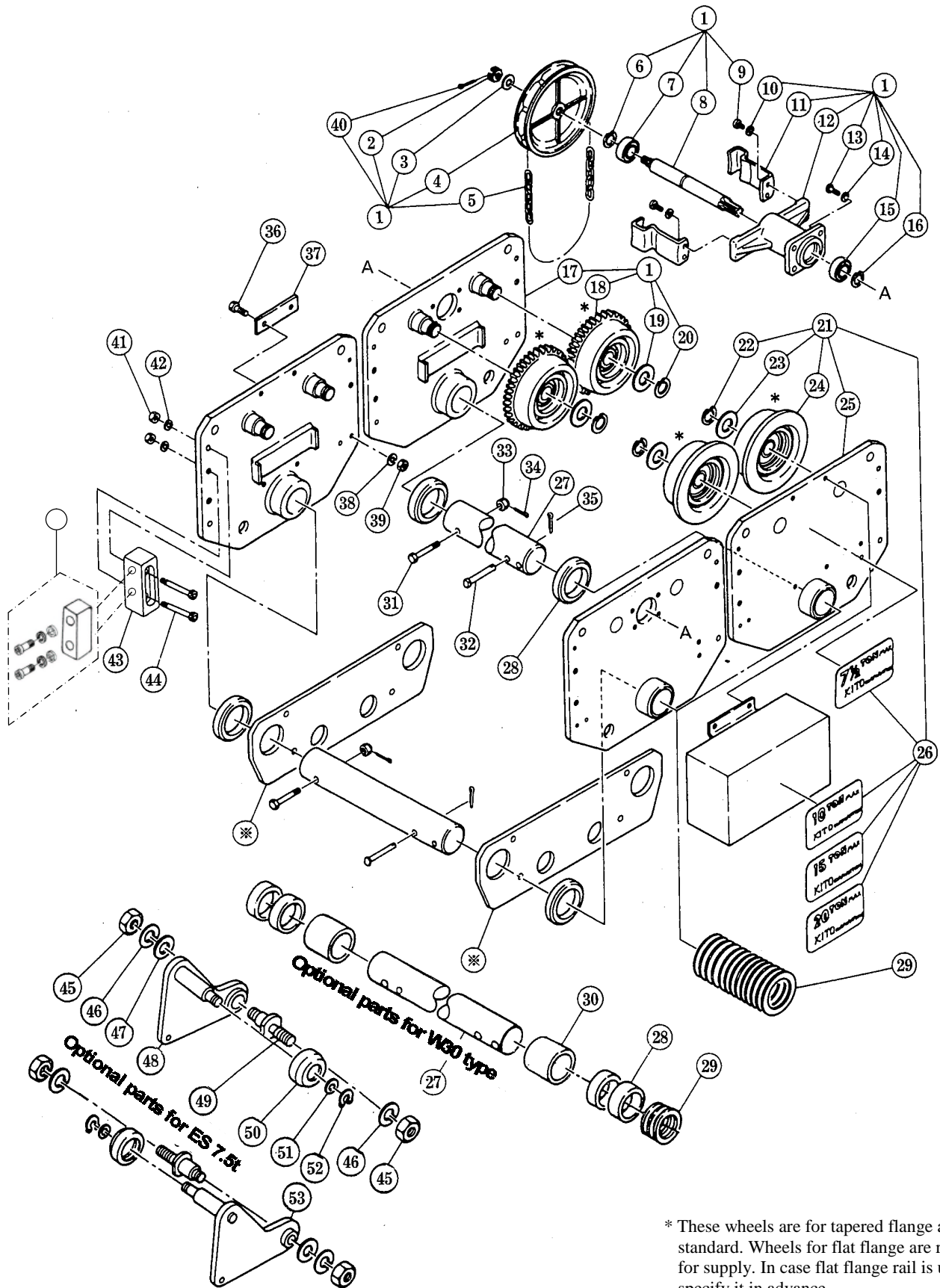

* These wheels are for tapered flange as standard. Wheels for flat flange are ready for supply. In case flat flange rail is used, specify it in advance.

Fig No.	Part No.	Part Name	Nos per Trolley			Capacity			
			7.5t, 10t	15t	20t	7.5t	10t	15t	20t
1		Side plate G complete set	1	2					
2	T3G151	Slotted nut	1	2					
3	T3G152	Washer	1	2					
4	T3G123	Hand wheel	1	2					
5	CF842	Hand chain	1	2					
6	T3G132	Snap ring	2	4					
7	T3G131	Ball bearing	2	4					
8	T3G121	Pinion	1	2					
9	T3G163	Socket bolt	4	8					
10	E6F854	Spring washer	4	8					
11	T3G125	Hand chain guide	2	4					
12	T3G122	Pinion holder	1	2					
13	M6F575	Socket bolt	4	8					
14	M6F576	Spring washer	4	8					
15	T3G131	Ball bearing	2	4					
16	T3G132	Snap ring	2	4					
17		Side plate G assembly	1	2					
18	T3G1101	Track wheel G assembly	1B*	2B*					
	T3G1108		1Z*	2Z*					
19	T3G104	Washer	4	8					
20	T3G106	Snap ring	4	8					
21		Side plate S complete set	1	2					
22	T3G106	Snap ring	4	8					
23	T3G104	Washer	4	8					
24	T3G1102	Track wheel S assembly	2B*	4B*					
	T3G1109		2Z*	4Z*					
25		Side plate S assembly	1	2					
26	T3G801	Name plate B	1	1					
27	MS115	Suspension shaft	1	2					
	MS181		1 [W]	2 [W]					
28	MS117	Thick spacer	See table 5-1 in page 6.						
29	MS118	Thin spacer	See table 5-1 in page 6.						
30	MS182	Fixing spacer	2 [W]	4 [W]					
31	MS161	Bolt	1	2					
32	MS164	Shaft stopper pin	1	2					
33	T3G154	Slotted nut	1	2					
34	T3G155	Split pin	1	2					
35	T3G157	Split pin	1	2					
36	MS106	Bolt		4					
37	MS105	Connection plate		2					
38	MS174	Spring washer		4					
39	T3G170	Nut		4					
40	T3G161	Split pin	1	2					
41	T5G144	Nut	8	8					
42	T5G143	Spring washer	8	8					
43	T5G141	Bumper	4	4					
44	T5G142	Socket bolt	8	8					
54	T5AB-1101	Buffer assembly	4	4					
*	Refer to hoist parts list.								
45	MS411	Nut	4						
46	MS413	Spring washer	4						
47	MS412	Washer	2						
48	MS5401	Hanger plate A assembly	1						
49	MS408	Bolt	2						
50	MS1405	Hanger wheel assembly	2						
51	MS407	Wheel washer	2						
52	MS415	Snap ring	2						
53	MS5402	Hanger plate B assembly	1						

Note : [W] indicates wide flange type.

: The parts given no part number in the above table can not be supplied.

* : Symbol Z means track wheel applied to flat rail ; symbol B to tapered flange rail.

13. CONTENTS OF EC DECLARATION OF CONFORMITY

We, **KITO Corporation**,
2000 Tsuijjarai, Showa-cho,
Nakakoma-gun, Yamanashi, 409-3853, Japan
declare under our sole responsibility that the products:

Plain trolley TSP / Geared trolley TSG, **model TS2**
in capacity range of 500 kg up to 5 tonnes
Geared trolley TSG, **model TS1**
in capacity range of 7.5 tonnes to 30 tonnes,

to which this declaration relates is in conformity with the following EC directives and standards.

EC directives:

Machinery Directive **2006/42/EC**

Harmonized standards:

EN ISO 12100:2010 **Safety of machinery**

EN 818-7:2002+A1:2008 **Short link chain for lifting purposes,
increased quality, grade V, certified by
Fachausschuss Metall und Oberflächenbehandlung**

EN 13157:2004+A1:2009 **Hand powered lifting equipment,
except for the requirement of "5.2.6 Operating effort"**

Authorized representative for the arrangement of the technical documents:

Udo Kleinevoß

Technical Manager

Kito Europe GmbH. 40549 Düsseldorf

KITO

URL. <http://www.kito.co.jp>

KITO Europe GmbH

Heerdter Lohweg 93, D-40549 Düsseldorf, Germany

TEL: +49-(0)211-528009-00

FAX: +49-(0)211-528009-59

E-mail: info@kito-europe.eu

URL: <http://www.kito.net/>

KITO corporation

Tokyo Head office:

SHINJUKU NS Building 9F, 2-4-1, Nishi-Shinjuku, Shinjuku-ku, Tokyo 163-0809, Japan

URL: <http://www.kito.com/>

Head office & Factory:

2000 Tsuijjarai Showa-Cho, Nakakoma-Gun, Yamanashi 409-3853, Japan

URL: <http://www.kito.com/>