

Parts No	NAME
1	T1 Transformer
2	F1 Fuse
3	B11 Electromagnetic Brake
4	CHM Counter/Hour Meter
5	G11 Rectifier
6	M11 Hoist Motor
7	M21 Trolley Motor
8	K~ Contactor
9	X~ Plug/Socket/Connector
10	TP~ Motor Thermal Protector
11	LS11 Upper Limit Switch
12	LS12 Lower Limit Switch
13	TB~ Terminal Block

Abbreviation	
Bk : Black	Gn/Ye : Green/Yellow
Rd : Red	
Wh : White	
Bn : Brown	
Gy : Gray	
Or : Orange	EM : Emergency Stop
Be : Blue	UP : UP
Gn : Green	DN : Down
Ye : Yellow	

Note

1.

Body Size	Chain Hoist (ER)	
	2Gear Deceleration	3Gear Deceleration
B	001H/003S	—
C	004L/005L	004L/005L
	Friction Clutch	Mechanical Friction Clutch
	003H/005S	—
D	010S	010L
E	020S/030S/032S	015S/016S/020L
F	—	025S/050S

2.Operation Type
 Hoist: Single Speed
 Trolley: Single Speed

3.Power Supply
 200V class,400V class,500V class
 50/60Hz,3Phase

4.Push Button Connection
 Direct Connection

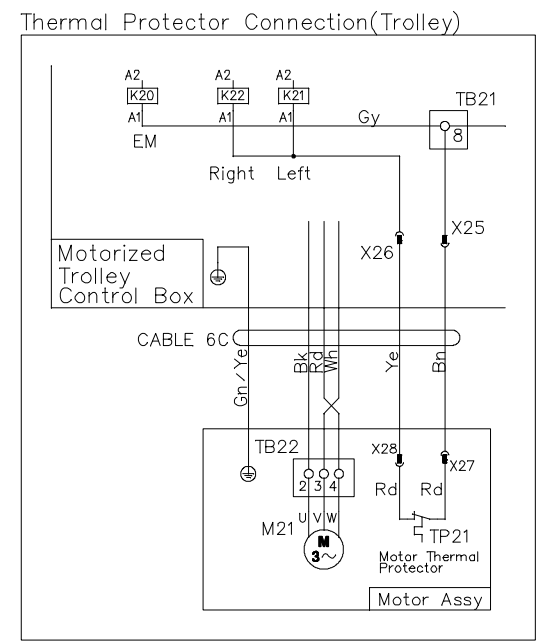
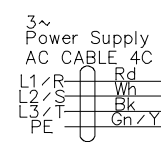
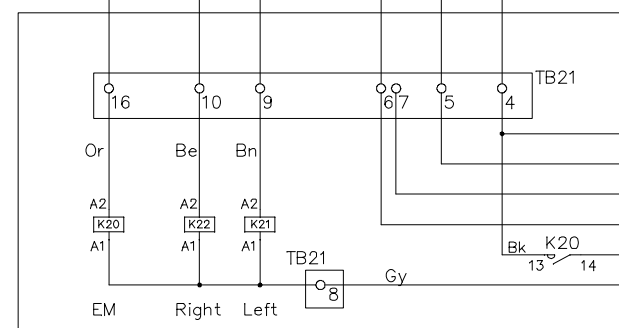
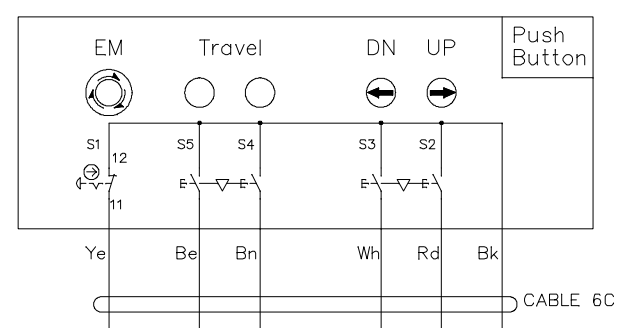
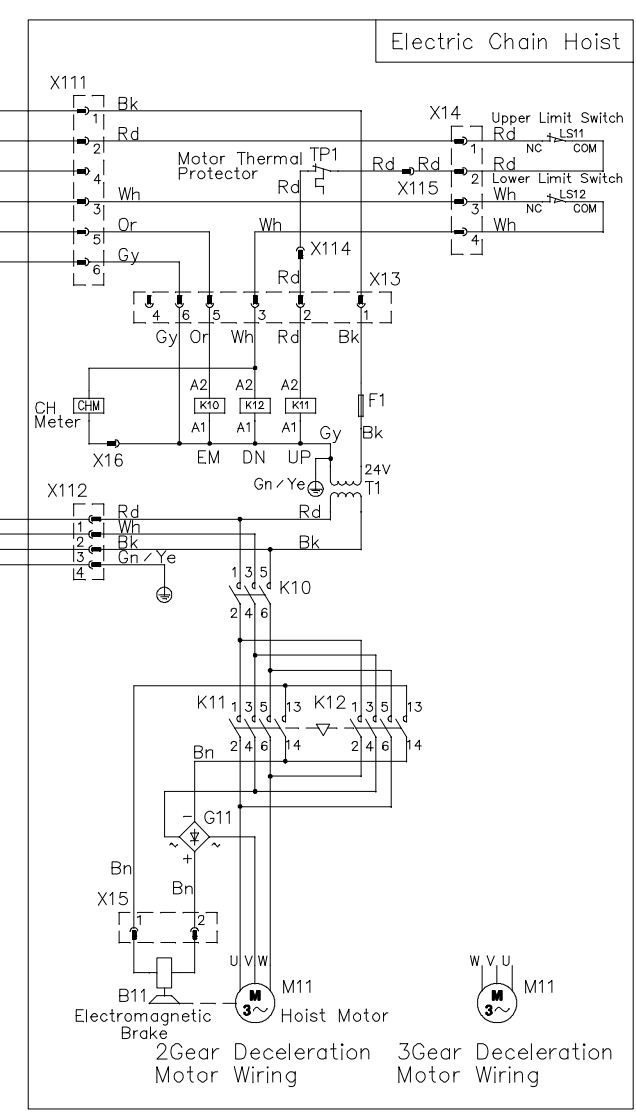
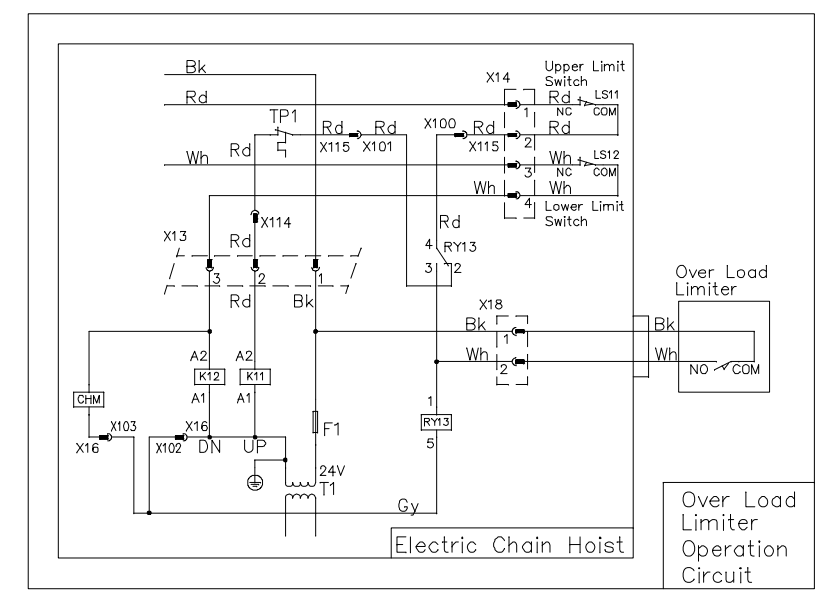

APPROVED	CHECKED	DESIGNED
K.Ishikawa	K.Koizumi	T.Hatano
08 / 08 / 23	08 / 08 / 23	08 / 08 / 23

Wiring Diagram

CODE	SCALE
DWG.NO. SK21C110BF	—
DATE	SCALE

KITO CORP.

UNIT : mm