

Parts No	NAME
1	T1 Transformer
2	F1 Fuse
3	B11 Electromagnetic Brake
4	G11 Rectifier
5	M11 Hoist Motor
6	M21 Trolley Motor
7	TP~ Motor Thermal Protector
8	LS11 Upper Limit Switch
9	LS12 Lower Limit Switch
10	X~,CN~ Plug/Socket/Connector
11	K~ Contactor
12	CHM Counter/Hour Meter
13	INV~ Inverter
14	I/F BRD~ Interface Board
15	R~ Resistance
16	RY~ Relay
17	CR~ Surge Absorber
18	TB~ Terminal Block
19	NF~ Noise Filter

Abbreviation	
Bk : Black	Gn/Ye : Green/Yellow
Rd : Red	
Wh : White	
Bn : Brown	
Gy : Gray	
Or : Orange	EM : Emergency Stop
Be : Blue	UP : UP
Gn : Green	DN : Down
Ye : Yellow	

Note

1.

Body Size	Chain Hoist (ER)	
	2Gear Deceleration	3Gear Deceleration
B	001H/003S	—
C	004L/005L	004L/005L
	Friction Clutch	Mechanical Friction Clutch
D	003H/005S	—
	010S	010L
E	020S/030S/032S	015S/016S/020L
F	—	025S/050S

2.Operation Type
 Hoist: Single Speed
 Trolley: Dual Speed(Inverter)

3.Power Supply
 200V class,400V class
 50/60Hz,3Phase

4.Push Button Connection
 Direct Connection

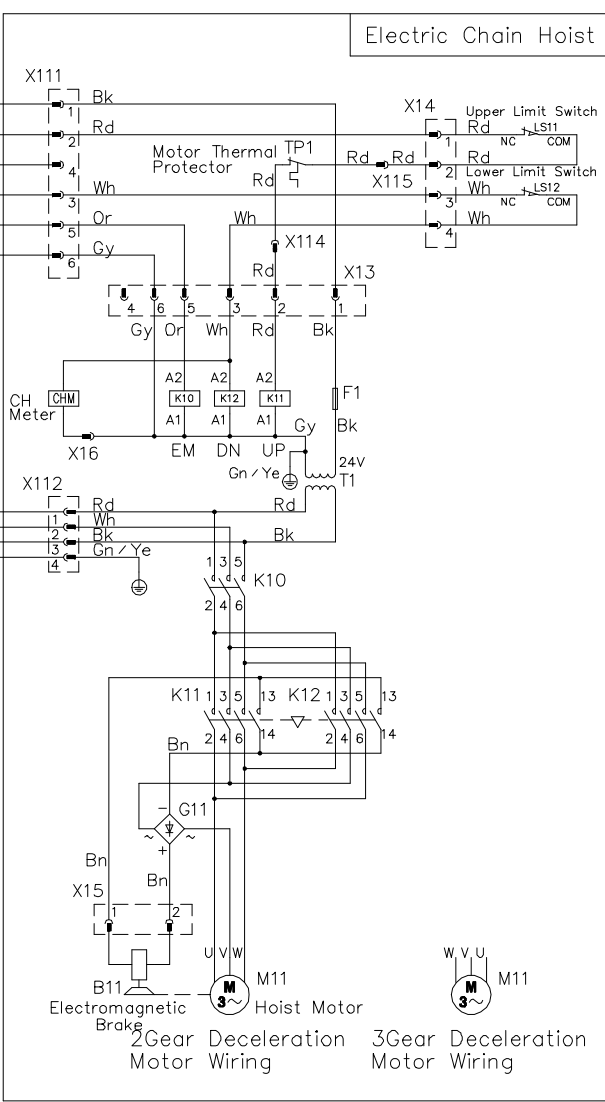
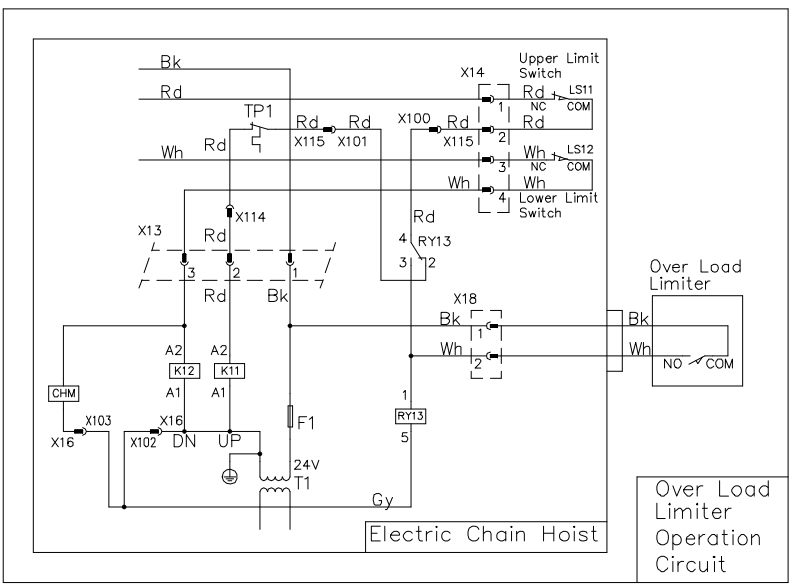
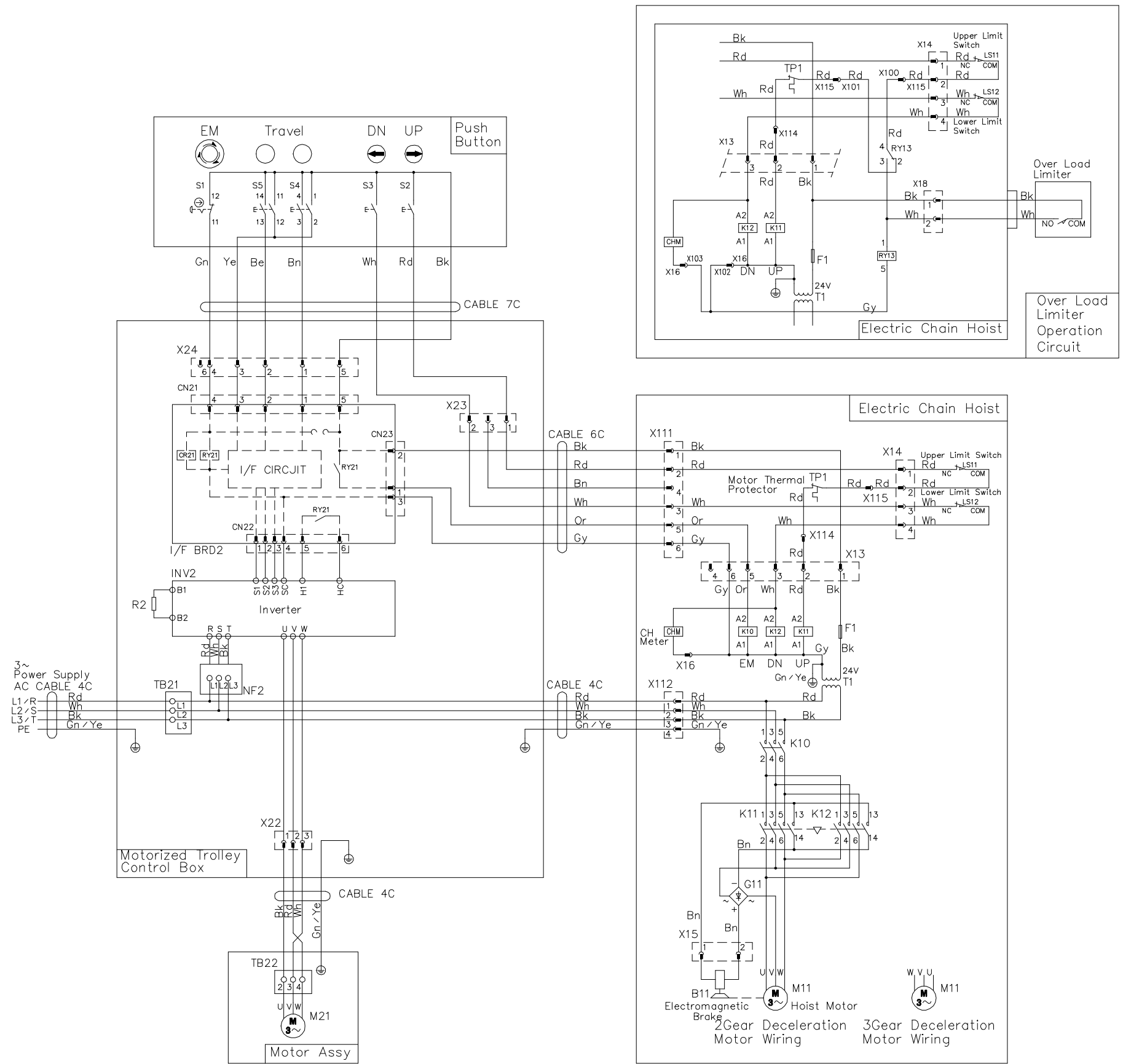

APPROVED	CHECKED	DESIGNED
H.Furiya	K.Koizumi	T.Hatano
09 / 04 / 17	09 / 04 / 17	09 / 04 / 17

Wiring Diagram(CE)

CODE	SCALE	—
------	-------	---

KITO CORP.

DWG.NO.	SK21C1D0BP	DATE	
---------	------------	------	--

UNIT : mm