



Original Instruction

**Supplement to Owner's (Operator's)
Manual for MODEL M3
30 TON TO 50 TON TYPE**

This manual just describes M3 series 30 TO 50 tonne,
please also refer to the standard Owner's (Operator's) Manual.

ALWAYS SAVE THIS BOOK FOR FUTURE REFERENCE.

KITO

Issued October 2000. Revised May, 2016(revision 04)

1. MAIN SPECIFICATIONS

(1) Refer to Sec. 4.....P.4 in the standard manual.

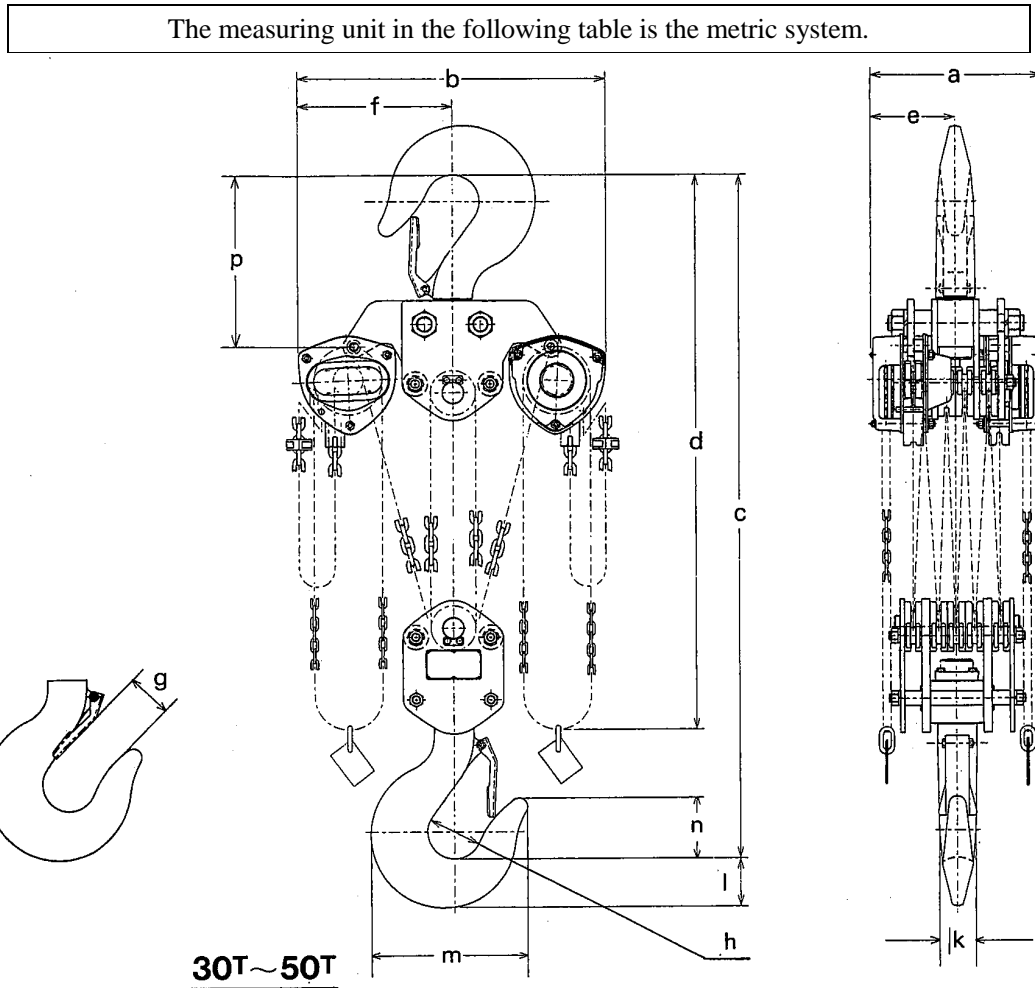

Specifications

Code	WLL (t)	Std. lift (m)	Chain pull to lift full load (N)	Chain o' hauled to lift load one meter (m)	Test load (t)	Net weight (kg)	Load chain dia: (mm) x pitch (mm)	Load chain fall (lines)	Weight for additional one meter of lift (kg)
CB300	30	3.5	430 x 2*	495 x 2	40	310	9.0 x 27.2	10	19.2
CB400	40	3.5	430 x 2*	693 x 2	50	480	9.0 x 27.2	14	26.2
CB500	50	3.5	490 x 2	792 x 2	62.5	640	9.0 x 27.2	16	29.7

- Any lift of chain is available on request. Because KITO chains are specially heat-treated, only authentic KITO chains should be used on your hoist. **Never** attempt to lengthen your chain by attaching additional chain links with any other means. KITO can supply almost any length of chain desired. Simply specify the length of chain desired when ordering.

* It does not conform to the requirement of "5.2.6 Operating effort" of the European standard EN 13157.

This device was tested on the required static and dynamic test provided on the European standard EN 13157.

Dimensions

Code	WLL (t)	Min. Distance between Hooks: C (mm)	a (mm)	b (mm)	d (mm)	e (mm)	f (mm)	g (mm)	h (mm)	k (mm)	l (mm)	m (mm)	n (mm)	p (mm)
CB300	30	1300	404	746	4.8	202	373	103	125	85	112	367	143	400
CB400	40	1480	502	760	4.9	251	380	104	140	95	125	420	160	445
CB500	50	1560	544	796	4.9	272	398	112	155	106	140	468	178	467

2. Periodic Inspection

<Regular Inspection Procedure>

The numbers in parenthesis are Figure NO. in this Supplement Parts List.

(1) Refer to Sec. 6.3.....P.9 in the standard manual.

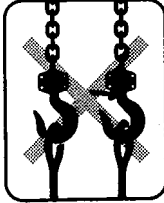
Item	Inspection Method	Discard Limit/Criteria	Measures
HOOK (44, 45, 65, 66) (Top and bottom) 1. Deformation/twist of hook opening 	Measure dimension "c" between two embossed or drilled marks at time of purchase with calipers.	○ No deformation from original shape (at time of purchase).	Replace the hook.
	Check visually.	○ Twist shall not be large enough to detect visually.	Replace the hook.
2. Wear	Measure "a" and "b" with slide caliper.	○ The dimensions shall not be more than 5% of the original.	Replace the hook.

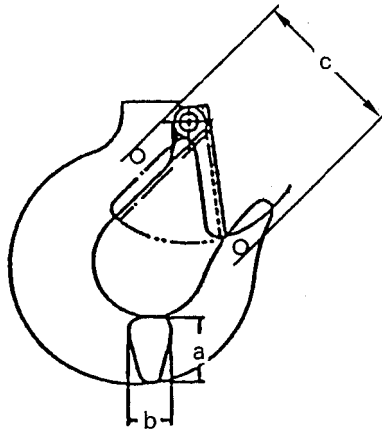
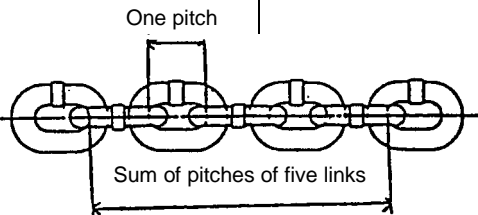

Table S1 (Reference dimensions)

WLL (t)	a (mm)		b (mm)	
	Normal	Discard	Normal	Discard
30	112	107	71	68
40	125	119	80	76
50	140	133	90	86

(2) Refer to Sec. 6.3.....P10 in the standard manual.

Item	Inspection Method	Discard Limit/Criteria	Measures						
LOAD CHAIN (36) 1. Wear	Measure with slide calipers.	○ Measure the sum of pitches of five chain links and check that the maximum length does not exceed value shown in table S2.	Replace the chain.						
		<p style="text-align: center;">Table S2</p> <table border="1"> <thead> <tr> <th>WLL (T)</th> <th>Sum of pitches of five links (mm)</th> <th>Discard limit (mm)</th> </tr> </thead> <tbody> <tr> <td>30, 40, 50</td> <td>136.0</td> <td>140.0</td> </tr> </tbody> </table>	WLL (T)	Sum of pitches of five links (mm)	Discard limit (mm)	30, 40, 50	136.0	140.0	
WLL (T)	Sum of pitches of five links (mm)	Discard limit (mm)							
30, 40, 50	136.0	140.0							

(3) Refer to Sec. 6.3.....P.12 in the standard manual.

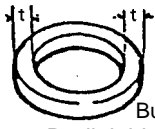
Item	Inspection Method	Discard Limit/Criteria	Measures						
<p>BRAKE 5. Bushing (28); wear and oil</p>	<p>Check radial thickness (t) with calipers and oil existence.</p>  <p>Bushing (28) t: Radial thickness</p>	<p>○ Radial thickness (t) shall be uniform. Oil shall be contained. Refer to table S3.</p> <p style="text-align: center;">Table S3</p> <table border="1" data-bbox="807 533 1441 645"> <thead> <tr> <th>Type (metric ton)</th> <th>Normal thickness: t (mm)</th> <th>Discard limit (mm)</th> </tr> </thead> <tbody> <tr> <td>30, 40, 50</td> <td>4</td> <td>3</td> </tr> </tbody> </table>	Type (metric ton)	Normal thickness: t (mm)	Discard limit (mm)	30, 40, 50	4	3	<p>Replace the part.</p>
Type (metric ton)	Normal thickness: t (mm)	Discard limit (mm)							
30, 40, 50	4	3							

3. PARTS LIST

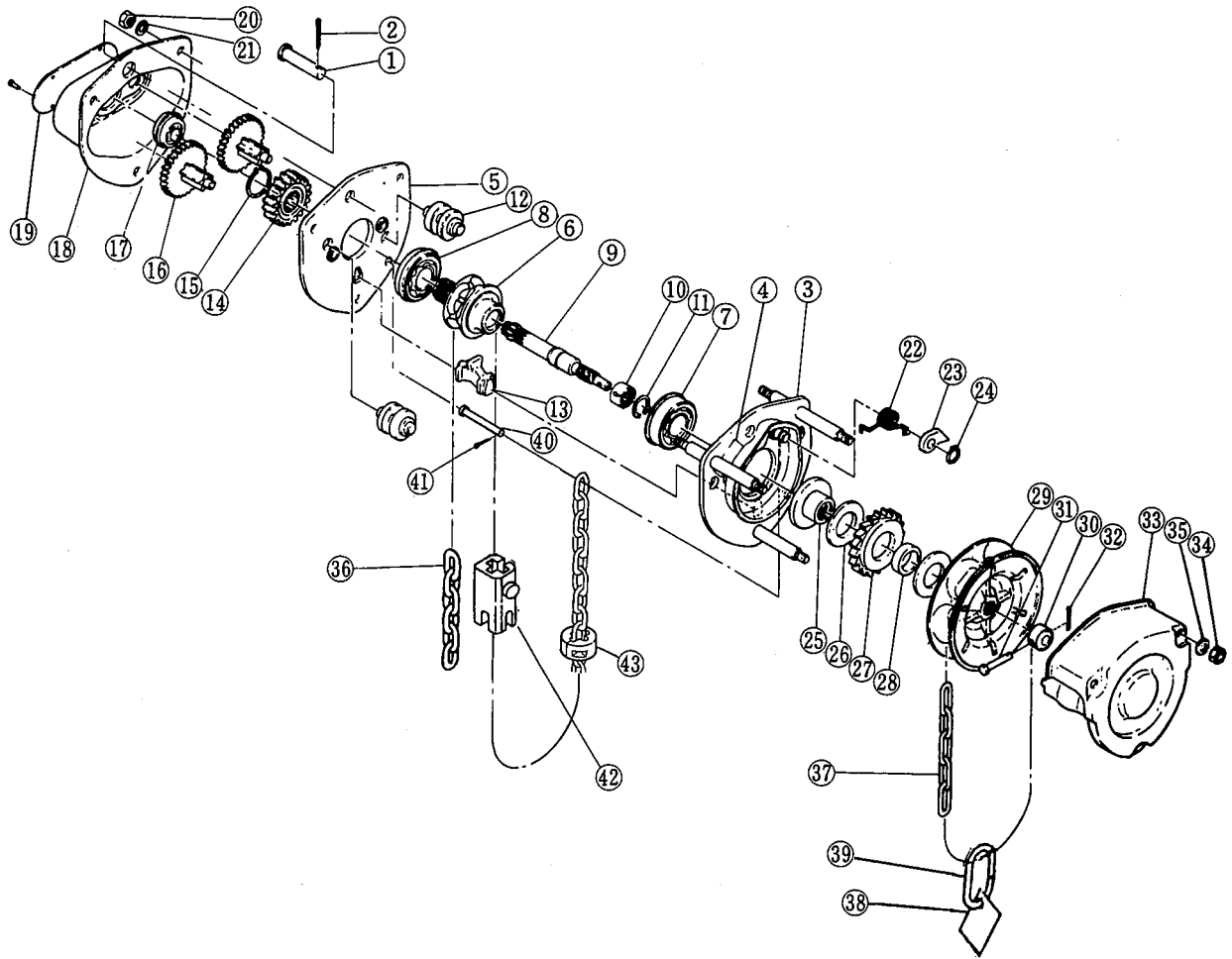

Fig. No.	Part No.	Part Name	No. per Hoist	WLL (t)		
				30	40	50
1	M3-163	Top pin	2			
2	M3-198	Split Pin	2			
3	M3B101	Side plate A assembly	2			
4	M3-806	Name plate F	2			
5	M3B102	Side plate B assembly	2			
6	M3-116	Load sheave	2			
7	M3-140	Ball bearing	2			
8	M3-145	Ball bearing	2			
9	M3B111	Pinion	2			
10	M3-130	Roller bearing	2			
11	M3-118	Snap ring	2			
12	M3B161	Guide roller	4			
13	M3-162	Stripper	2			
14	M3-114	Load gear	2			
15	M3-117	Snap ring	2			

Fig. No.	Part No.	Part Name	No. per Hoist	WLL (t)		
				30	40	50
16	M3B112	Gear #2 assembly	4			
17	M3-135	Ball bearing	2			
18	M3-103	Gear case assembly	2			
19	M3B800	Name plate B with rivets	2			
20	M3-181	Nut	6			
21	M3-186	Spring washer	6			
22	M3-179	Pawl spring A *	2			
	M3-180	Pawl spring B *	2			
23	M3-155	Pawl	2			
24	M3-157	Snap ring	2			
25	M3B153	Friction disc	2			
26	M3B151	Friction plate	4			
27	M3B152	Ratchet disc	2			
28	M3B154	Bushing	2			
29	M3B115	Hand wheel	2			
30	M3-159	Wheel stopper	2			
31	M3-167	Wheel stopper pin	2			
32	M3-199	Split pin	2			
33	M3-171	Wheel cover assembly	2			
34	M3-182	Nut	6			
35	M3-187	Spring washer	6			
36	M3-841	Load chain	2			
37	M3-842	Hand chain	2			
38	M3-931	Warning tag	2			
39	L4-045	Chain stopper link	2			
40	M3-164	End pin	2			
41	M3-197	Split pin	2			
42	M3-176	Cross guide	2			
43	M3-045	Stopper assembly	4			

* Pawl spring A and B must be used as a set.

ADDITIONAL PARTS

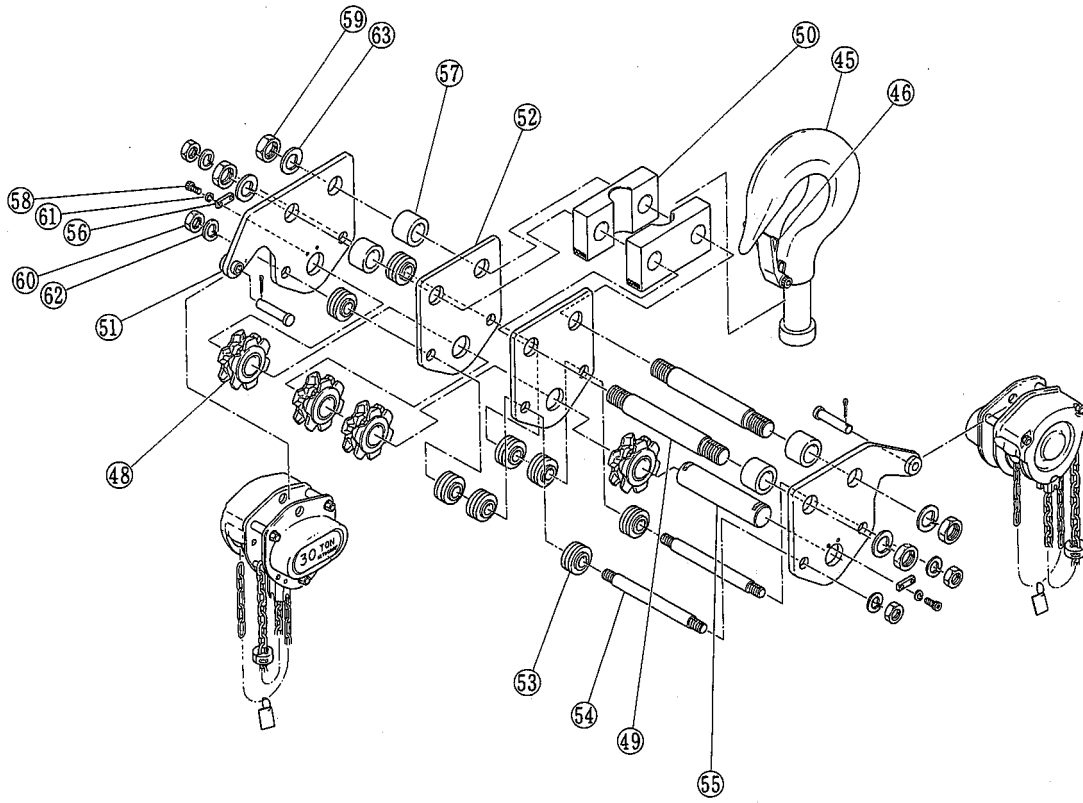

Fig. 44 Top hook set for 30t

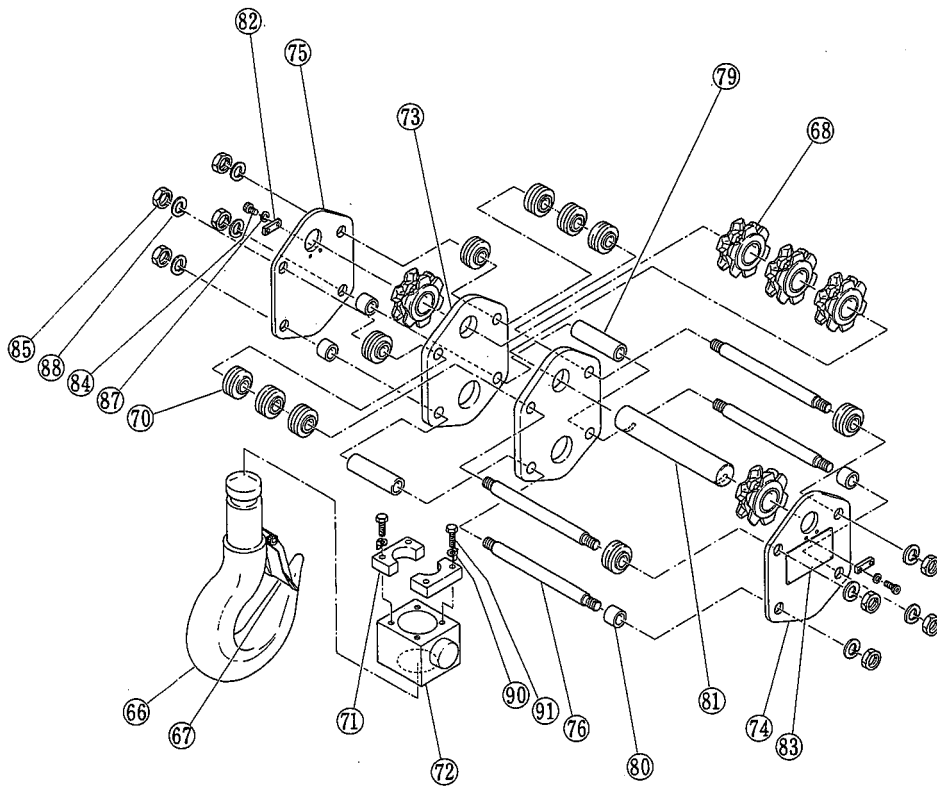

Fig. 65 Bottom hook set for 30t

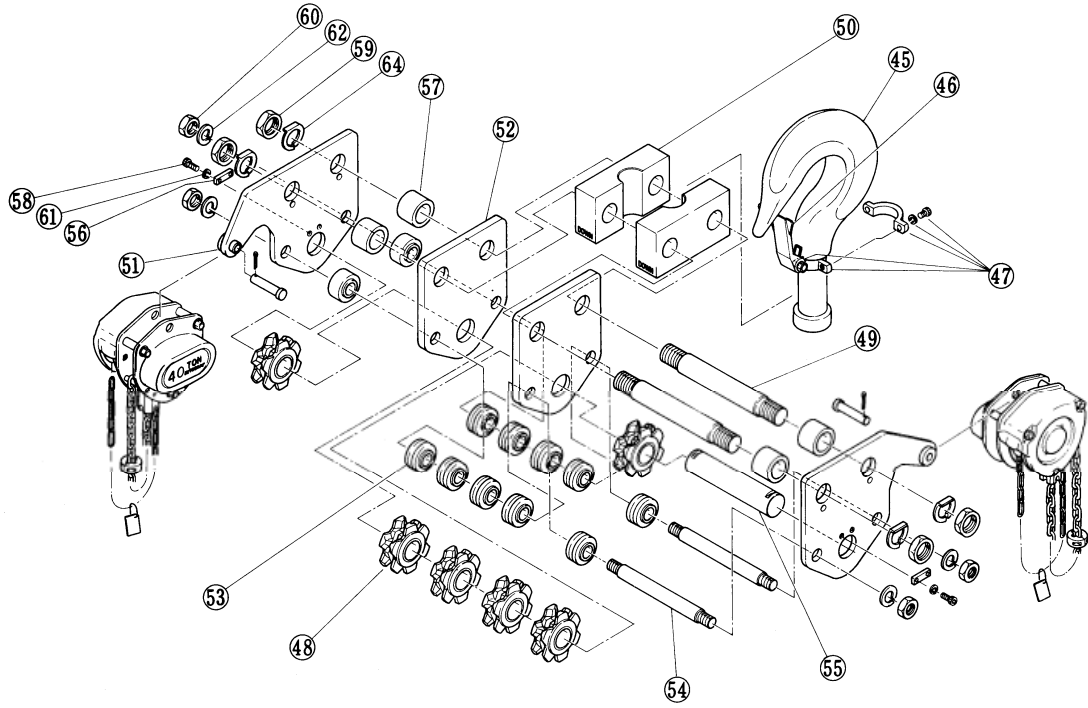

Fig. 44 Top hook set for 40t

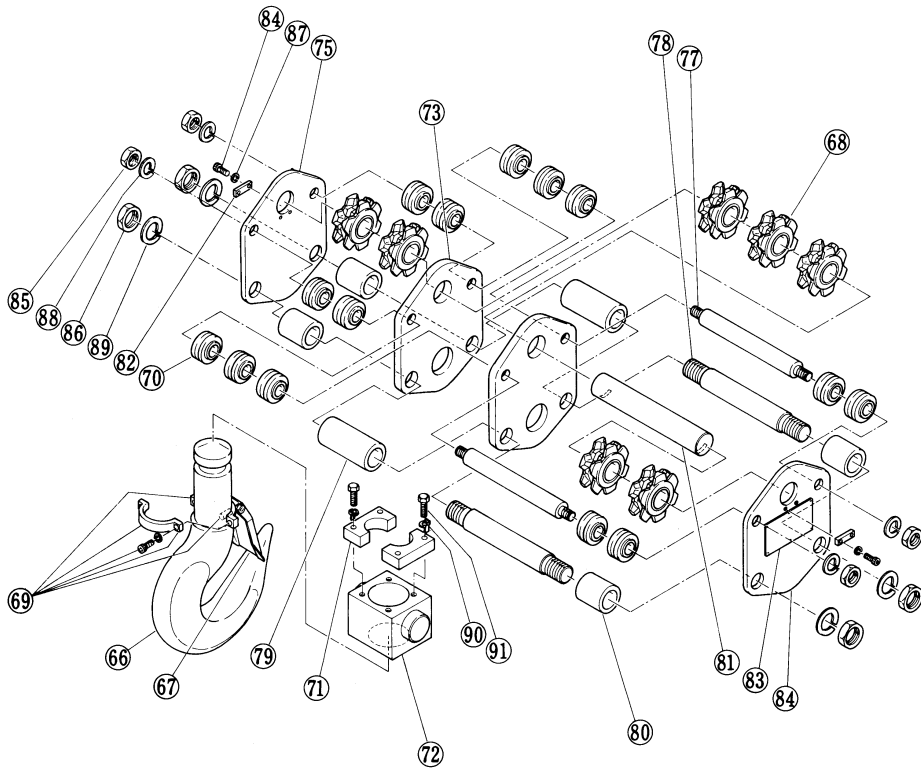

Fig. 65 Bottom hook set for 40t

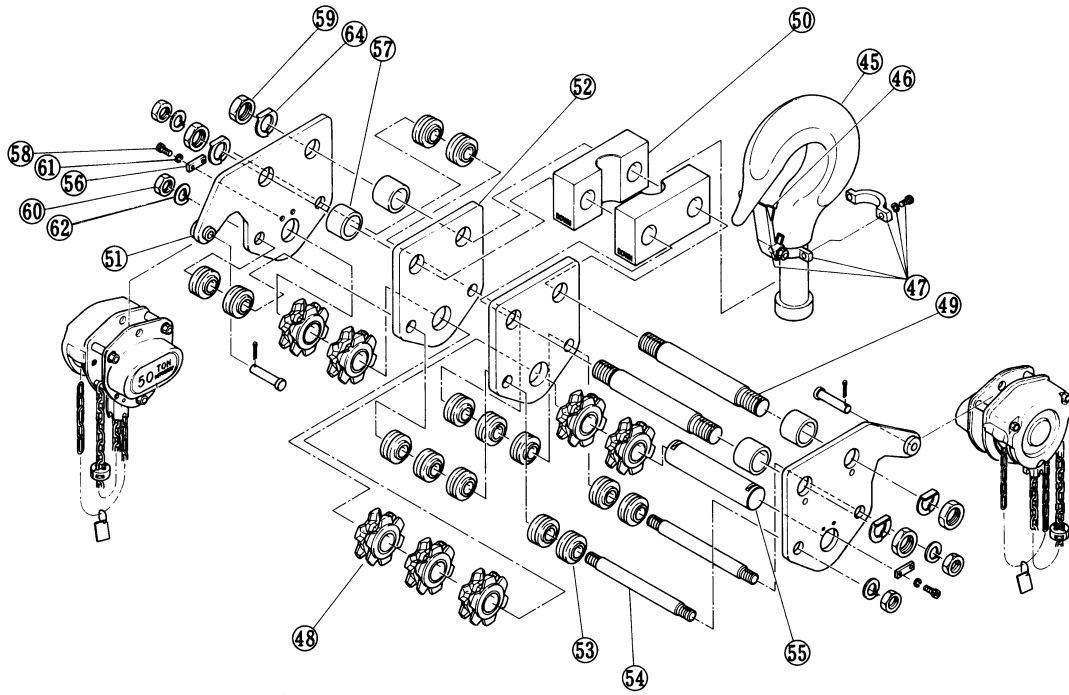

Fig. 44 Top hook set for 50t

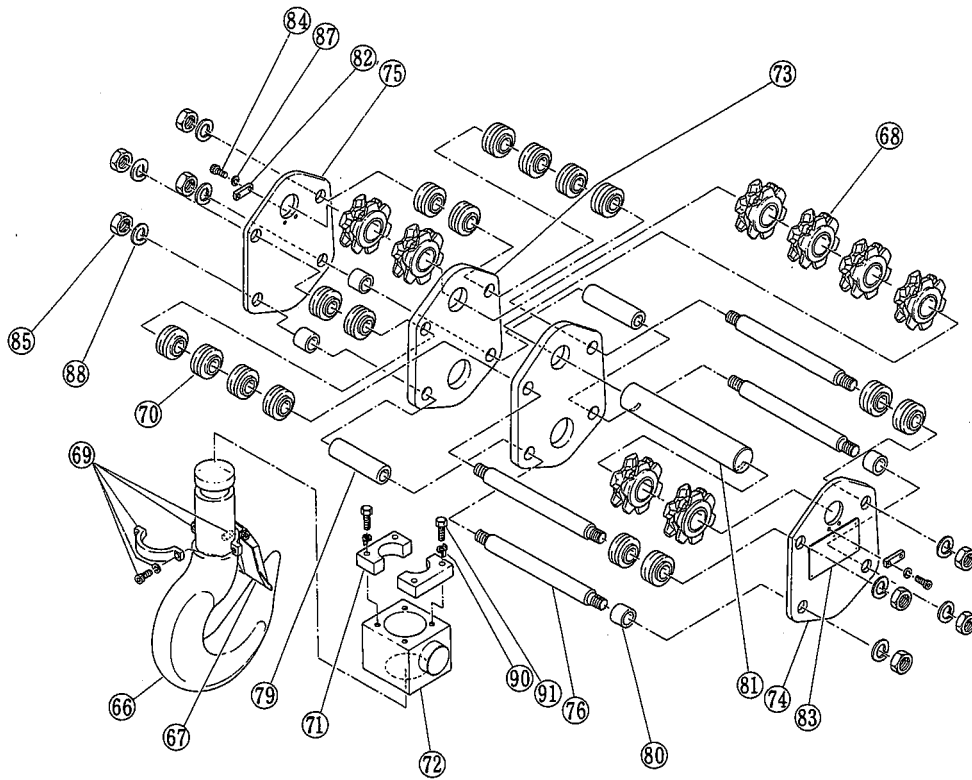

Fig. 65 Bottom hook set for 50t

Fig. No.	Part No.	Part Name	No. per Hoist	WLL (t)		
				30	40	50
44	M3-001A	Top hook set	1			
45	M3-001	Top hook	1			
46	M3-072	Hook latch assembly	1			
47	M2-076	Lever holder assembly	1	—		
48	M3-051	Idle sheave assembly		4	6	7
49	M3-010	Top suspension shaft	2			
50	M3-011	Top yoke	2			
51	M3-012	Top plate A assembly	2			
52	M3-114	Top plate C	2			
53	M3-018	Guide		8	12	14
54	M3-019	Stay bolt	2			
55	M3-053	Top shaft	1			
56	M2-056	Key plate	2			
57	M3-027	Collar	4			
58	M3-083	Socket bolt	4			
59	M3-084	Nut	4			
60	M3-085	Nut	4			
61	M3-087	Spring washer	4			
62	M3-088	Spring washer	4			
63	M3-089	Spring washer	4			
64	M2-089	Pawled washer	4	—		
65	M3-021A	Bottom hook set	1			
66	M3-021	Bottom hook	1			
67	M3-072	Hook latch assembly	1			
68	M3-051	Idle sheave assembly		5	7	8
69	M2-076	Lever holder assembly	1	—		
70	M3-018	Guide		10	14	16
71	M3-026	Hook support	2			
72	M3-030	Bottom yoke	1			
73	M3-034	Bottom plate A	2			
74	M3-035	Bottom plate B	1			
75	M3-036	Bottom plate C	1			
76	M3-038	Stay bolt	4		—	
77	M3-037	Stay bolt A	2	—		—
78	M3-038	Stay bolt B	2	—		—

Each number in "Capacity Code" columns is nos. per hoist.

Fig No.	Part No.	Part Name	No. per Hoist	WLL (t)		
				30	40	50
79	M3-039	Collar A	2			
80	M3-040	Collar B	4			
81	M3-054	Bottom shaft	1			
82	M2-056	Key plate	2			
83	M3-069	Name plate A with rivets	1			
84	M3-083	Socket bolt	4			
85	M3-085	Nut		8	4	8
86	M3-086	Nut	4	—		—
87	M3-087	Spring washer	4			
88	M3-088	Spring washer	8			
89	M3-090	Spring washer	4	—		—
90	M3-091	Tongued washer	4			
91	M3-092	Bolt	4			

Each number in "WLL" columns is no. per hoist.

KITO

URL. <http://www.kito.co.jp>

KITO Europe GmbH

Heerdter Lohweg 93, D-40549 Düsseldorf, Germany

TEL: +49-(0)211-528009-00

FAX: +49-(0)211-528009-59

E-mail: info@kito-europe.eu

URL: <http://www.kito.net/>

KITO corporation

Tokyo Head office:

SHINJUKU NS Building 9F, 2-4-1, Nishi-Shinjuku, Shinjuku-ku, Tokyo 163-0809, Japan

URL: <http://www.kito.com/>

Head office & Factory:

2000 Tsuijjarai Showa-Cho, Nakakoma-Gun, Yamanashi 409-3853, Japan

URL: <http://www.kito.com/>